

Cleco®

Pneumatic Power Motors

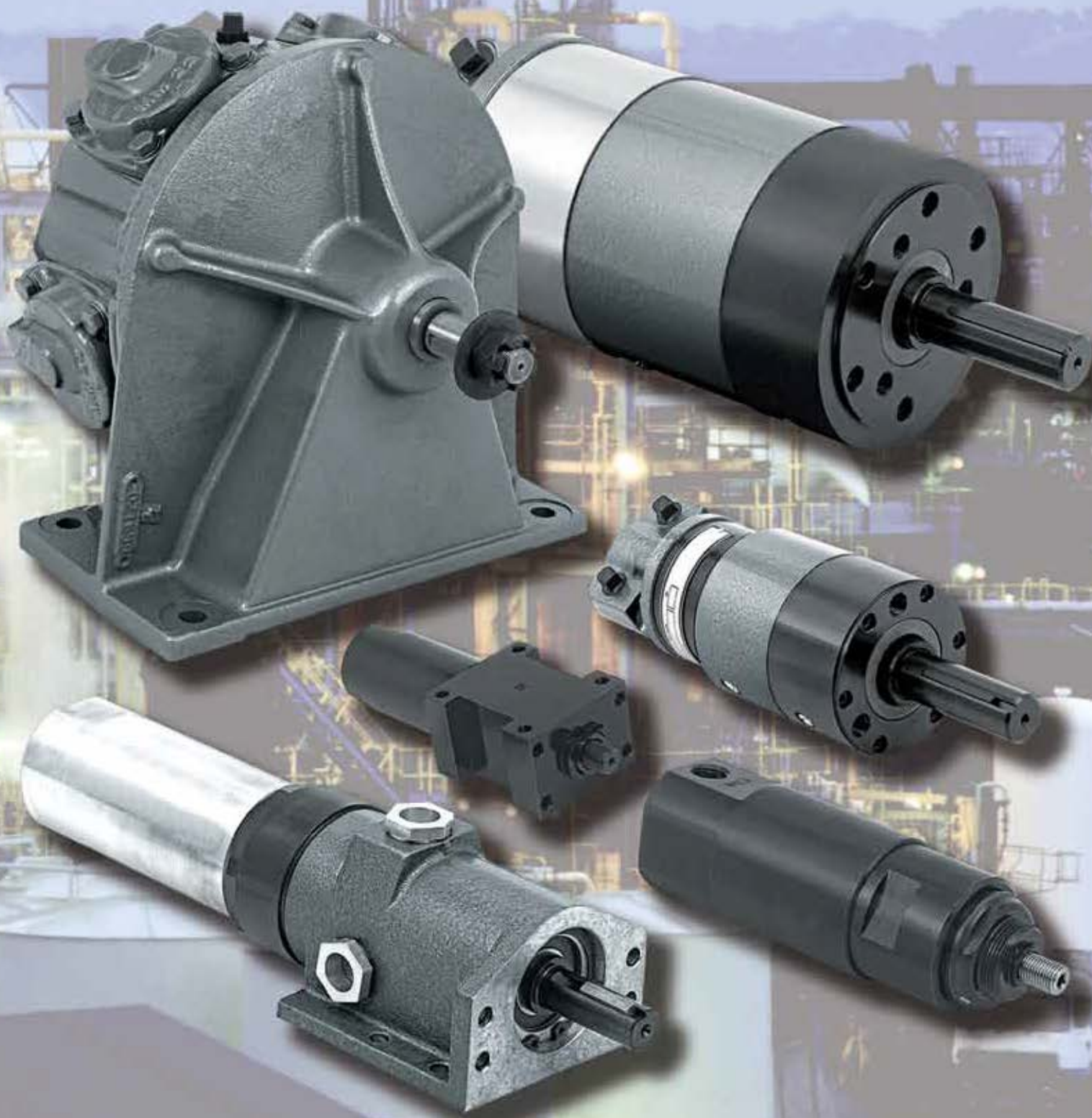

Model Number Index	2
Warranty.....	3
Mountable Power Motors	4-5
Rotary Vane Motors	6-45
21 Series	6-9
22 Series	10-15
Optional Equipment for 21 & 22 Series Motors ...	16
Accessories for 21 & 22 Series Motors.....	17
21MF & 21MR Series	18-19
31MF & 31MR Series	20-21
41MF & 41MR Series	22-23
61MF & 61MR Series	24-25
Accessories for MF & MR Series Motors	26
C3 Series.....	28-29
41 Series	30-31
60 Series	32-33
MR Series	34-41
Axial Piston Motors.....	42-51
A2 Series	42-43
B4 Series.....	44-45
A6 Series	46-47
A8 Series	48-49
Spindle Information for Axial Piston Motors	50
Radial Piston Motors	52-64
MA2 Series	52-53
MA3 Series	54-55
MB Series	56-57
ME Series	58-59
MK Series	60-61
MM Series.....	62-63
Throttle Combinations for Radial Piston Motors... ..	64
General Accessories.....	64-65
Conversion Tables.....	66-67

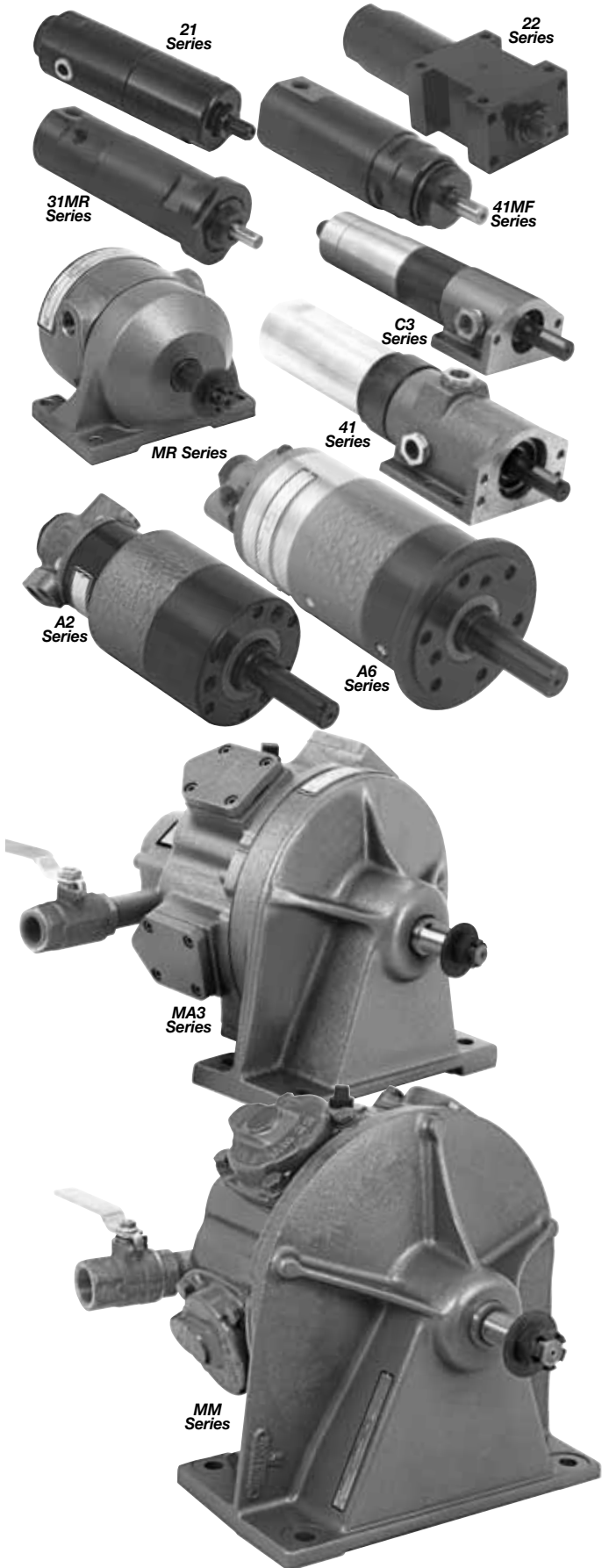

Model Number Index

Model	Page	Model	Page	Model	Page	Model	Page
21-1000	8	31MFN915M	20	B4R319M	44	MMW421M	61
21-1041	6	31MFN916M	20	B4R320M	44	MMW422M	61
21-1042	6	31MFN917M	20	B4R321M	44	MMW423M	61
21-1340	6	31MRR911M	21	B4R322M	44	C3R039M	29
21-1900	8	31MRR912M	21	B4R323M	44	C3R040M	29
22-5000	12	31MRR914M	21	A6R331M	46	C3N041M	28
22-5002	12	31MRR916M	21	A6R332M	46	C3N043M	28
22-5042	10	31MRR917M	21	A6R333M	46	C3N044M	28
22-5070	14	41MFN901M	22	A6R335M	46	C3N045M	28
22-5340	10	41MFN902M	22	A8R336M	48	C3R046M	29
22-5440	10	41MFN905M	22	A8R337M	48	C3R047M	29
22-5940	10	41MFN907M	22	A8R338M	48	C3R048M	29
21M1000	8	41MFN908M	22	MA2S352M	52	C3R050M	29
21M1002	8	41MFN911M	22	MA2R353M	52	C3N051M	28
21M1040	6	41MFN912M	22	MA2R355M	52	C3N054M	28
21M1300	8	41MFN915M	22	MA2S356M	52	C3N055M	28
21M3140	6	41MFN916M	22	MA3S358M	54	MR10R097M	34
21M1540	6	41MFN917M	22	MA3R359M	54	MR10R098M	34
22M5000	12	41MFN918M	22	MA3S360M	54	MR10R099M	34
22M5001	12	41MRR911M	23	MA3R361M	54	MR10R100M	34
22M5002	12	41MRR912M	23	MA3S370M	54	MR10R101M	34
22M5040	10	41MRR914M	23	MA3R371M	54	MR10R102M	34
22M5041	10	41MRR915M	23	MA3S372M	54	MR30R103M	36
22M5042	10	41MRR916M	23	MA3R373M	54	MR30R104M	36
22M5070	14	41MRR917M	23	MBS374M	56	MR30R105M	36
22M5071	14	41MRR918M	23	MBS376M	56	MR30R106M	36
22M5072	14	61MFN911M	24	MBR377M	56	MR30R107M	36
22M5270	14	61MFN912M	24	MBR379M	56	MR30R110M	36
22M5300	12	61MFN913M	24	MBS380M	56	MR30R111M	36
22M5340	10	61MFN914M	24	MBR381M	56	MR30R112M	36
22M5370	14	61MFN915M	24	MES384M	58	MR50R114M	38
22M5400	12	61MRR912M	25	MER385M	58	MR50R115M	38
22M5440	10	61MRR913M	25	MES386M	58	MR50R116M	38
22M5940	10	61MRR914M	25	MER387M	58	MR50R117M	38
21MFN900M	18	61MRR915M	25	MER389M	58	MR50R118M	38
21MFN901M	18	41N043M	30	MKS390M	60	MR70R119M	40
21MFN902M	18	41N075M	30	MKR391M	60	MR70R120M	40
21MFN903M	18	41N124M	30	MKS392M	60	MR70R121M	40
21MFN906M	18	41N172M	30	MKR393M	60	MR70R122M	40
21MFN907M	18	41N236M	30	MKR395M	60	MR70R123M	40
21MFN910M	18	41R032M	31	MMS396M	62	MR70R124M	40
21MFN911M	18	41R044M	31	MMR397M	62	60N195M	32
21MFN912M	18	41R056M	31	MMR399M	62	60N196M	32
21MFN914M	18	41R075M	31	MMS400M	62	60N198M	32
21MFN915M	18	41R092M	31	MMR401M	62	60N199M	32
21MFN916M	18	41R128M	31	MA3W403M	52	60R200M	33
21MFN917M	18	41R176M	31	MA3W404M	52	60R201M	33
21MRR912M	19	A2R300M	42	MA3W406M	52	60R202M	33
21MRR913M	19	A2R301M	42	MA3W407M	52	60R203M	33
21MRR914M	19	A2R302M	42	MA3W408M	52	60R204M	33
21MRR917M	19	A2R303M	42	MA3W409M	52		
31MFN900M	20	A2R304M	42	MBW410M	55		
31MFN901M	20	A2R305M	42	MBW411M	55		
31MFN902M	20	A2R306M	42	MBW412M	55		
31MFN903M	20	A6R307M	45	MBW413M	55		
31MFN904M	20	A6R308M	45	MEW414M	57		
31MFN905M	20	A8R309M	47	MEW415M	57		
31MFN906M	20	A8R310M	47	MEW417M	57		
31MFN907M	20	A8R311M	47	MKW418M	59		
31MFN910M	20	B4R317M	44	MKW419M	59		
31MFN912M	20	B4R318M	44	MKW420M	59		

Warranty

Apex Tool Group warrants products and parts sold by it, insofar as they are of its own manufacture, against defects of material and workmanship, under normal use and service in accordance with its written instructions, recommendations, and ratings for installation, operation, maintenance, and service of products, for a period of **ONE YEAR FROM THE DATE OF INITIAL USE, BUT IN NO EVENT SHALL THE WARRANTY EXCEED 24 MONTHS FROM DATE OF DELIVERY TO DISTRIBUTOR.** Proof of Purchase with shipment date must be furnished by the user to validate the warranty. This warranty applies only to products manufactured by Apex Tool Group and specifically excludes products manufactured by others. Products not manufactured by Apex Tool Group are warranted only to the extent and in the manner warranted to Apex Tool Group by the manufacturer

and then only to the extent Apex Tool Group is able to enforce such warranty. Apex Tool Group's warranty with respect to products manufactured by it is limited to the repair or replacement, as Apex Tool Group may elect, of any defective part regarding which the Distributor has given 5 days written notice from the discovery of such defect. Installation and transportation costs are not included. Apex Tool Group shall have the option of requiring the return to it of the defective material, transportation prepaid, for inspection. No allowance will be made for repairs without Apex Tool Group's approval. **APEX TOOL GROUP MAKES NO OTHER WARRANTY OF ANY KIND WHATSOEVER, EXPRESSED OR IMPLIED, AND HEREBY DISCLAIMS ALL WARRANTIES OF MERCHANTABILITY AND FITNESS FOR A PARTICULAR PURPOSE.**

Lubrication Products

Apex Tool Group's products are classified as non-hazardous manufactured items, defined in the OSHA 1910.1200 Hazard Communication Standard as "Articles". These products, under conditions of normal use, do not release or cause exposure to a hazardous chemical.

Under normal conditions of use, lubrication products sold separately for or used within these tools should not cause an exposure hazard. Refer to the Material Safety Data Sheet (M.S.D.S.) for Safety and Disposal Information. M.S.D.S. sheets are available upon request from Apex Tool Group.

Apex Tool Group is also aware of, and complies with, the provisions of section 611 amendments

to the Clean Air Act of 1990. No ozone depleting chemicals have been used in the manufacture of our products.

If you resell or distribute these products, you have the responsibility for ensuring that the Material Safety Data Sheets are provided to the purchaser.

Proper lubrication is essential to the economical operation of pneumatic and electric tools. Apex Tool Group tools perform better and their life is extended by using the recommended lubricants. All lubricants that are listed in the accessory section of this catalog have undergone extensive testing and are recommended for use with Cleco products.

Choose the right Air Motor to fit your application

Apex Tool Group's air motors are engineered for flexibility and reliability. Cleco air motors cover a wide range of uses where compressed air is advantageous: powering air driven machinery, raising foundry copes and drags, rotating a turntable, mixing paint, powering cranes, valve actuation, or power source for mechanical hands or universal joints.

Rotary Vane Air Motors

Apex Tool Group offers two types of rotary vane air motors, the large Cleco MR series (1.0 to 7.5 hp) with spring loaded blades and small to medium sizes (.14 to 2.3 hp). All motors feature durable construction with precision heavy-duty bearings throughout, and multiple blade rotors for smooth power. There is a wide range of speeds and torques as well as a choice of foot, face, or flange mounting. These motors require air line lubrication for long, trouble-free service. Mount the lubricator as close to the motor as possible. These motors perform satisfactorily in high temperature areas up to 200°F (93° C).

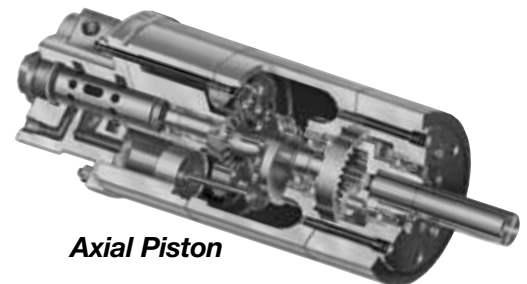
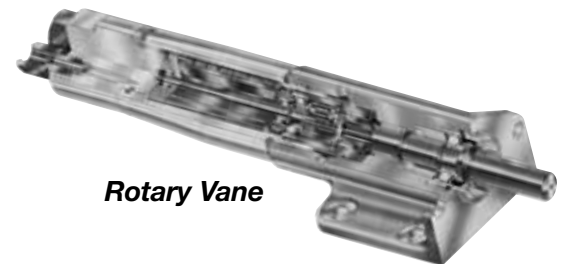
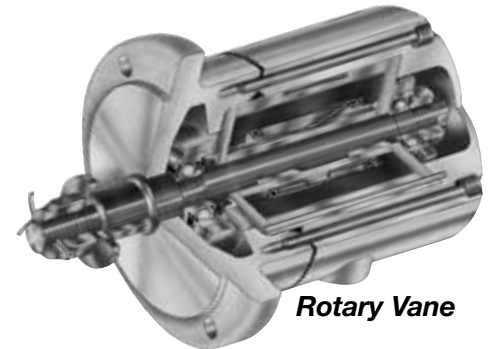

Axial Piston

These small, lightweight Cleco motors are ideal for installation in close quarters. The rugged construction and precision manufacturing of these motors allows long life with minimum maintenance. Generous size spindle bearings permit overhung weight on spindle with no external support.

High torque is an inherent characteristic of piston type air motors, making them especially desirable for applications involving heavy starting loads. The overlap of power impulses in axial piston air motors provides even torque and full power in either direction of rotation. These motors should be operated under load and horizontally. Axial piston motors are ideal for start stop operations. It is not recommended that they be operated at speeds greater than 75% of free speed. Their enclosed type construction allows operation in corrosive or dusty atmospheres. These motors perform satisfactorily in high temperature areas up to 200° (93° C). Grease fittings are provided for lubrication. It is recommended that air lines be equipped with filters and lubricators. Mount the lubricator as close to the motor as possible.

Radial Piston

Heavy-duty construction make these motors suitable for continuous operation. The counterbalanced crankshaft is supported by anti-friction bearings. A slinger distributes oil to all moving parts of the motor. Oil level and drain plugs are easily accessible.

High torque is an inherent characteristic of piston type air motors, making them especially desirable for applications involving heavy starting loads. The overlap of power impulses in radial piston air motors provides even torque and full power in either direction of rotation. At least two pistons are always on a power stroke. These motors should be operated under load and in a horizontal position. It is not recommended that they be operated at speeds greater than 75% of free speed.

These motors perform satisfactorily in high temperature areas up to 200° (93° C). It is recommended that air lines be equipped with lubricators. Mount the lubricator as close to the motor as possible.

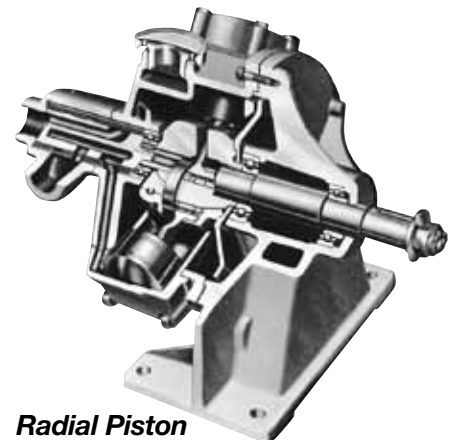

Air Motor Selection

To assist in the selection of an air motor, we need any two of the following three items of information:

1. Horsepower required.
2. Speed (RPM) required against load.
3. Work load expressed in foot pounds or inch pounds of dynamic torque (moving torque load).

As air motors are dependent upon input air pressure for performance, these factors must also be considered:

1. Air pressure (psig or bars) at motor location.
2. Pipe size of air supply system to assure adequate volume (cfm or m³/min) so as to minimize line loss (air pressure drop during motor operation).
3. Plant air system pressure may vary during the day due to use by other equipment; therefore, base the selection of the air motor on the lowest psig or bars that can be expected. Then, by using a pressure regulator in the line at the motor, a uniform air supply is assured.

In applications of intermittent short service, Cleco air motors can be operated over the complete range indicated for each without harm or significant wear. In applications involving sustained continuous operation for long periods, however, some guidelines are suggested. **Do not operate piston and MR motors at more than 75% of free speed.** Consult the factory for applications requiring continuous operation of rotary vane motors at maximum HP or for any applications requiring vertical operation of these motors. Review service manuals carefully.

For two known and one unknown, the following formulas can be used:

$$\text{Ft. lbs. Torque} = \frac{1000 \times \text{HP}}{0.19 \times \text{RPM}}$$

$$\text{Horsepower (HP)} = \frac{0.19 \times \text{Torque (ft. lbs.)} \times \text{RPM}}{1000}$$

$$\text{Speed (RPM)} = \frac{1000 \times \text{HP}}{0.19 \times \text{Torque (ft. lbs.)}}$$

When working with Newton meters (Nm), substitute .0258 in place of 0.19 in the formula.

Use the performance charts provided for each motor size and type for obtaining this same data procedure:

1. Select operating pressure.
2. Select torque required from the left hand scale.
3. Extend that point position across chart until it intersects with torque performance curve of the selected pressure.
4. Draw a vertical line from the above mentioned intersection to the corresponding motor scale at the bottom of the chart to determine the operating speed at the required torque and psig pressure.
4. Extend the vertical line until it intersects the horsepower curve of selected operating pressure and read horsepower from the motor scale on the right side of the chart.

Torque and horsepower curves may be interpreted for approximate performance at other psi pressure.



21 Series

- Maximum Power
0.3 hp
0.22 kW
- Torque Range
0.2 – 15.2 ft. lbs.
0.27 – 20.6 Nm
- Non-Reversible
- Rear Exhaust



21M1340-40

21-1340-40

Spindle Rotation

All models are right-hand rotation. To order left-hand rotation models (*not reversible*) substitute “D” for the first “-” in the model number for round housing motors and “V” for the “M” in the model number for motors with flange and base mounting.

IMPORTANT: Threaded spindles have right-hand threads; therefore use keyed shaft models only (-49) for left-hand rotation.

Model Number*	RPM		Stall Torque		Weight		Gear Ratio	Length (page 7)		
	at Max. hp	Free Speed	ft lbs.	Nm	lbs.	kg		Overall (A) in.	Pilot (B) in.	
Round Housing – 3/8” Diameter Keyed Spindle										
21-1041-49	300	600	9.9	13.41	2.1	.95	44.82:1	5.66	.25	
21-1042-49	450	900	6.4	8.67	2.1	.95	29.1:1	5.66	.25	
21-1340-49	1600	3200	1.8	2.44	1.6	.73	8.3:1	4.34	.25	
21-1940-49	15000	30000	0.2	0.27	1.2	.54	—	3.00	.69	
Flange and Base Mounting – 3/8” Diameter Keyed Spindle										
21M1041-49	300	600	9.9	13.41	3.0	1.36	44.82:1	5.66	.25	
21M1340-49	1600	3200	1.8	2.44	2.5	1.13	8.3:1	4.34	.25	
21M1540-49	2500	5000	1.2	1.63	2.5	1.13	5.4:1	4.34	.25	

General:

Air Inlet: 1/4” NPT – Side and rear
 Air consumption: 12 cfm (.34 m³/min)
 All tools performance rated @ 90psi (620 kPa) air pressure.

***Optional Terminations:**

Replace -49 in model number with the desired termination when ordering.
 -38 0”-1/4” Capacity Drill Chuck (5000 RPM or less)
 -51 1/16”-3/8” Capacity Drill Chuck (5000 RPM or less)
 -40 3/8”-24 Threaded Spindle
 -01 Series 200 Collet Chuck (for milling and routing)
 -36 Series 300 Collet Chuck (for milling and routing)

Standard Equipment:

Hex socket screw provided for closure of unused inlet. Flush fitting for lubrication of gears. Wrench for threaded spindle and collet chuck models. 1/4” collet included with series 200 & 300 collet chuck.

Optional Equipment:

Exhaust mufflers, remote-exhaust hoses, air intake hoses, spindle adapters and filter-lubricator-regulators available at extra cost. Any series 200 collet may be substituted at no additional cost. On series 300 collet chuck, collets 301, 302, and 303 are available at extra cost. Any other series 300 collet may be substituted at no additional cost.

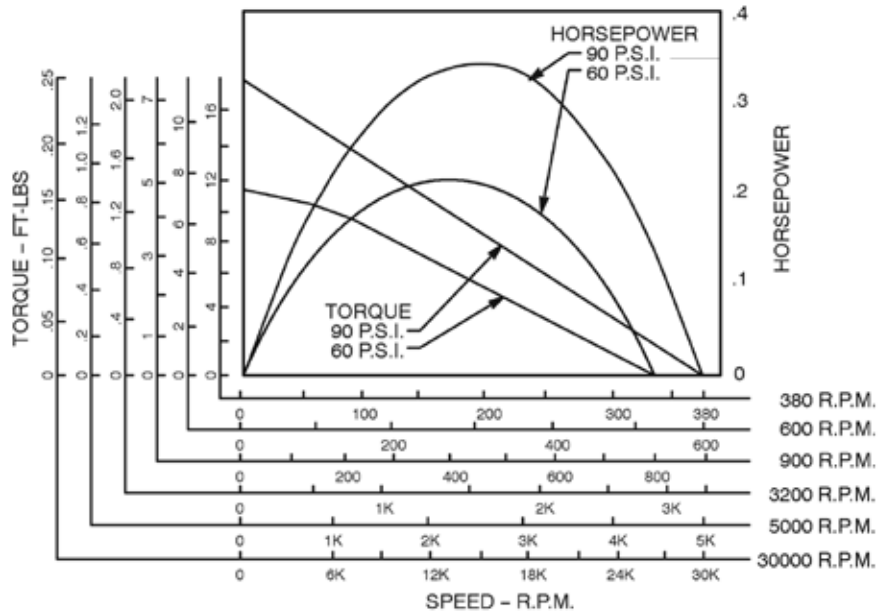
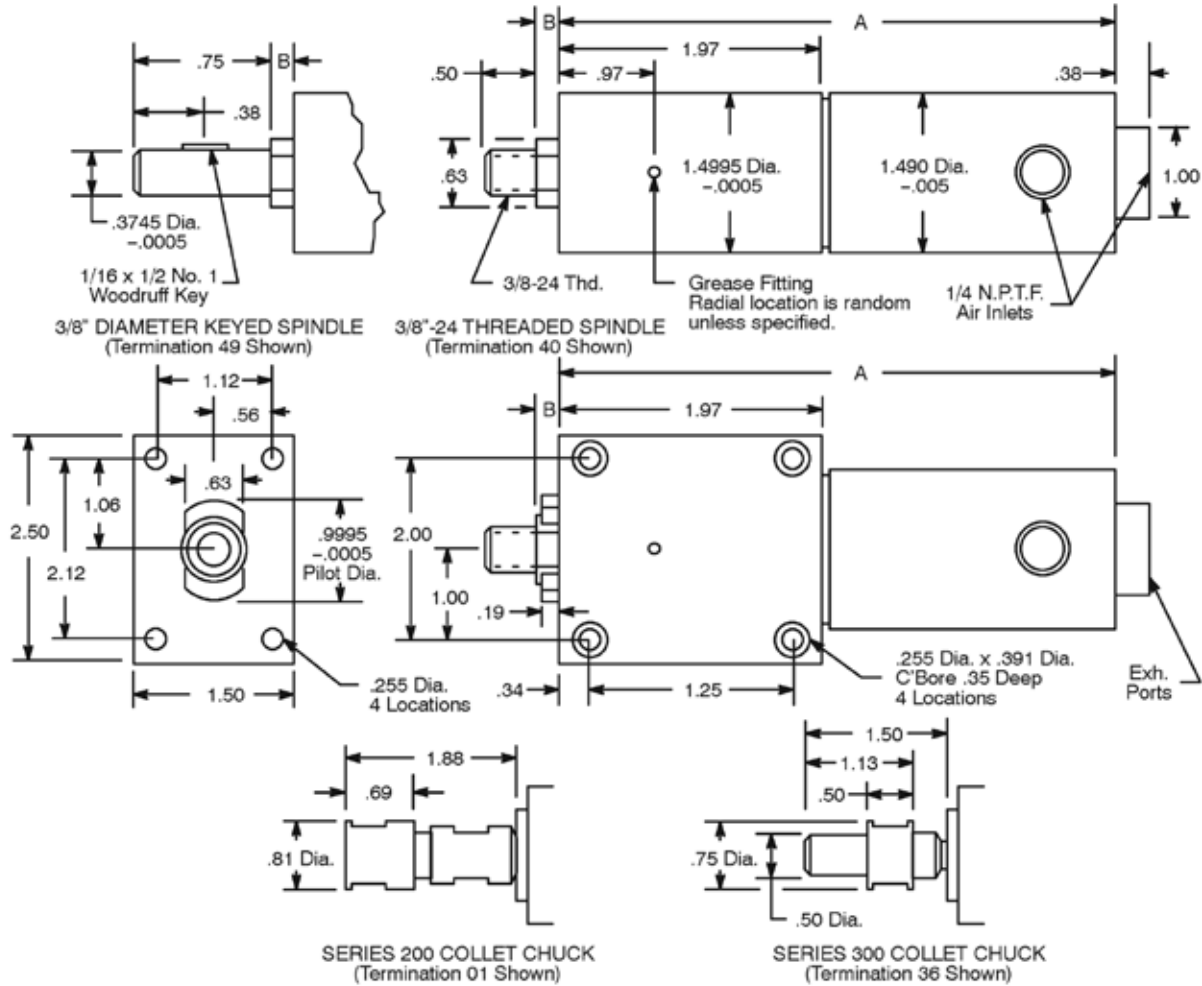

Important:

A 5/16" I.D. air inlet hose may be used for runs up to 10'. For longer runs, use 3/8" I.D. hoses. Planetary gears should be greased after every 250 hours with gear grease # 45-0983, or equivalent. For Filters, Regulators and Lubricators refer to page 64. If air line connector is used, install at end of hose away from the tool.

Concentricity:

On motors with round housings, concentricity of spindle to O.D. of housing is .003 TIR.



21 Series

- Maximum Power
0.3 hp
0.22 kW
- Torque Range
0.2 – 15.2 ft. lbs.
0.27 – 20.6 Nm
- Non-Reversible
- Side Exhaust



Spindle Rotation

All models are right-hand rotation. To order left-hand rotation models (*not reversible*) substitute “D” for the first “-” in the model number for round housing motors and “V” for the “M” in the model number for motors with flange and base mounting.

IMPORTANT: Threaded spindles have right-hand threads; therefore use keyed shaft models only (-49) for left-hand rotation.

Model Number*	RPM		Stall Torque		Weight		Gear Ratio	Length (page 9)		
	at Max. hp	Free Speed	ft. lbs.	Nm	lbs.	kg		Overall (A) in.	Pilot (B) in.	
Round Housing – 3/8” Diameter Keyed Spindle										
21-1000-49	190	380	15.2	20.60	2.3	1.04	68.9:1	5.66	.25	
21-1900-49	15000	30000	0.2	0.27	1.3	.59	—	3.00	.69	
Flange and Base Mounting – 1/2” Diameter Keyed Spindle										
21M1000-49	190	380	15.2	20.60	3.1	1.41	68.9:1	5.66	.25	
21M1002-49	450	900	6.4	8.67	3.1	1.41	29.1:1	5.66	.25	
21M1300-49	1600	3200	1.8	2.44	2.6	1.18	8.3:1	4.34	.25	

General:

Air Inlet: 1/4” NPT – Side and rear
Air consumption: 12 cfm (.34 m³/min)
All tools performance rated @ 90psi (620 kPa) air pressure.

*Optional Terminations:

Replace -49 in model number with the desired termination when ordering.

- 38 0”-1/4” Capacity Drill Chuck (5000 RPM or less)
- 51 1/16”-3/8” Capacity Drill Chuck (5000 RPM or less)
- 40 3/8”-24 Threaded Spindle
- 01 Series 200 Collet Chuck (for milling and routing)
- 36 Series 300 Collet Chuck (for milling and routing)

Standard Equipment:

Hex socket screw provided for closure of unused inlet. Flush fitting for lubrication of gears. Wrench for threaded spindle and collet chuck models. 1/4” collet included with series 200 & 300 collet chuck.

Optional Equipment:

Exhaust mufflers, remote-exhaust hoses, air intake hoses, spindle adapters and filter-lubricator-regulators available at extra cost. Any series 200 collet may be substituted at no additional cost. On series 300 collet chuck, collets 301, 302, and 303 are available at extra cost. Any other series 300 collet may be substituted at no additional cost.

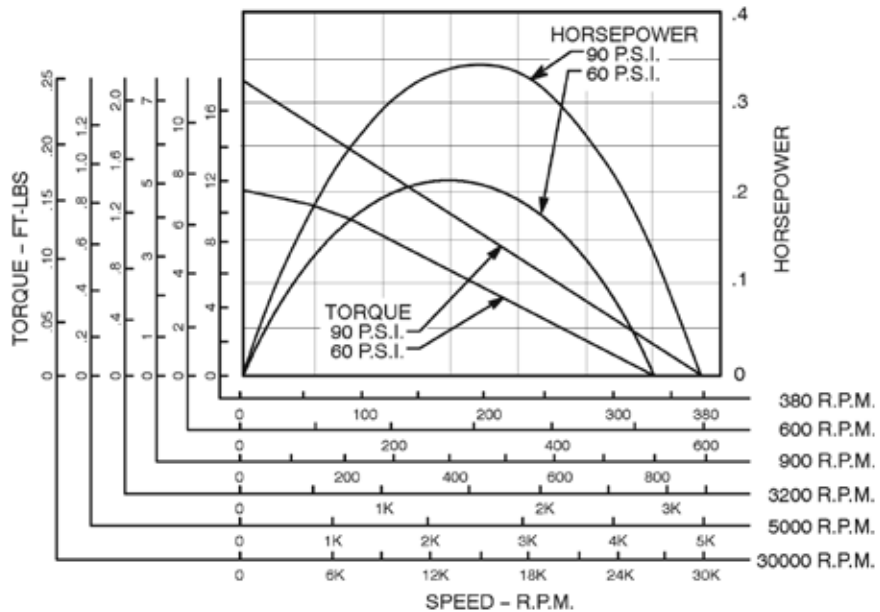
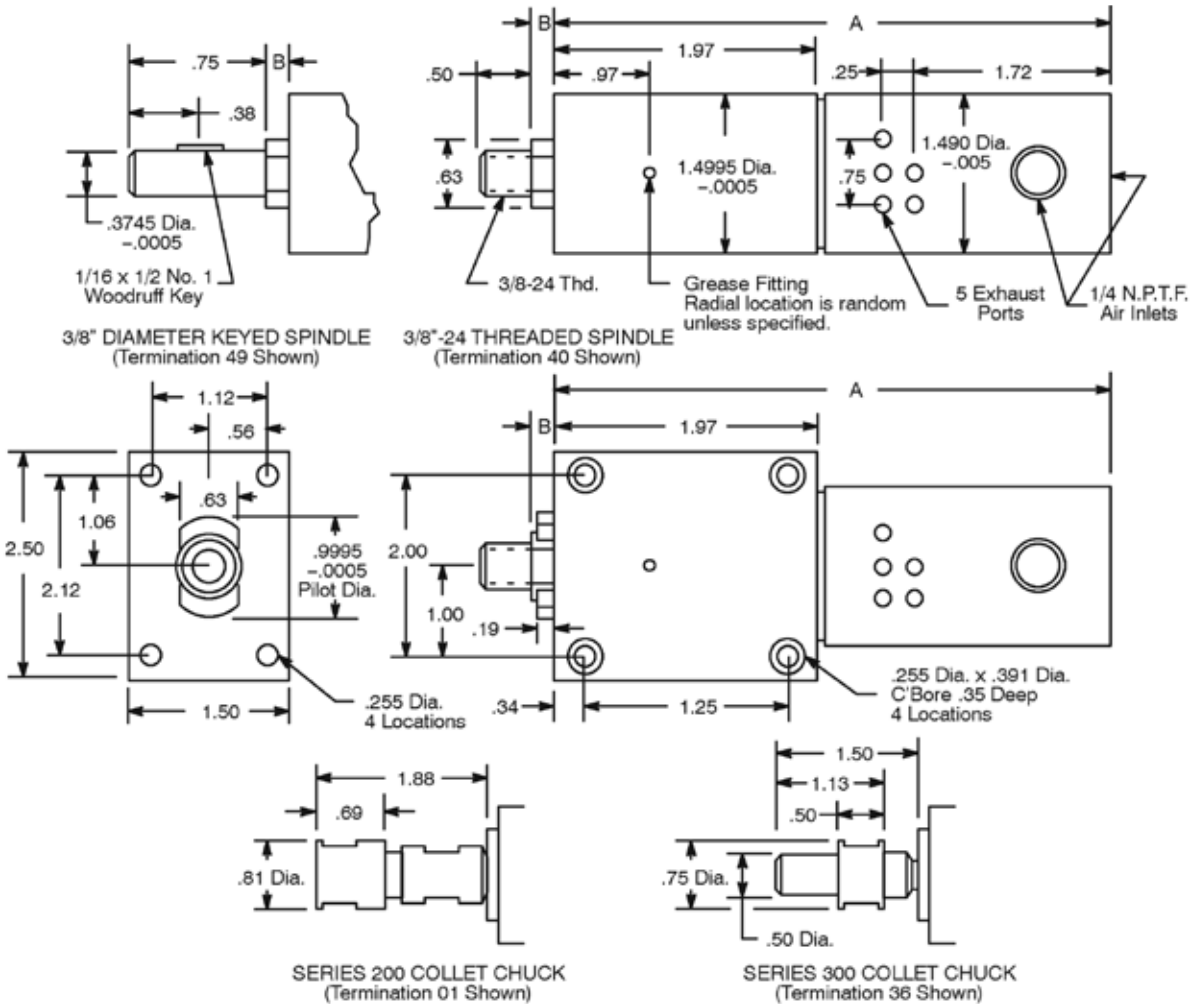

Important:

A 5/16" I.D. air inlet hose may be used for runs up to 10'. For longer runs, use 3/8" I.D. hoses. Planetary gears should be greased after every 250 hours with gear grease # 45-0983, or equivalent. For Filters, Regulators and Lubricators refer to page 64. If air line connector is used, install at end of hose away from the tool.

Concentricity:

On motors with round housings, concentricity of spindle to O.D. of housing is .003 TIR.



22 Series

- Maximum Power
0.9 hp
0.67 kW
- Torque Range
0.8 – 41.2 ft. lbs.
1.08 – 55.83 Nm
- Non-Reversible
- Rear Exhaust

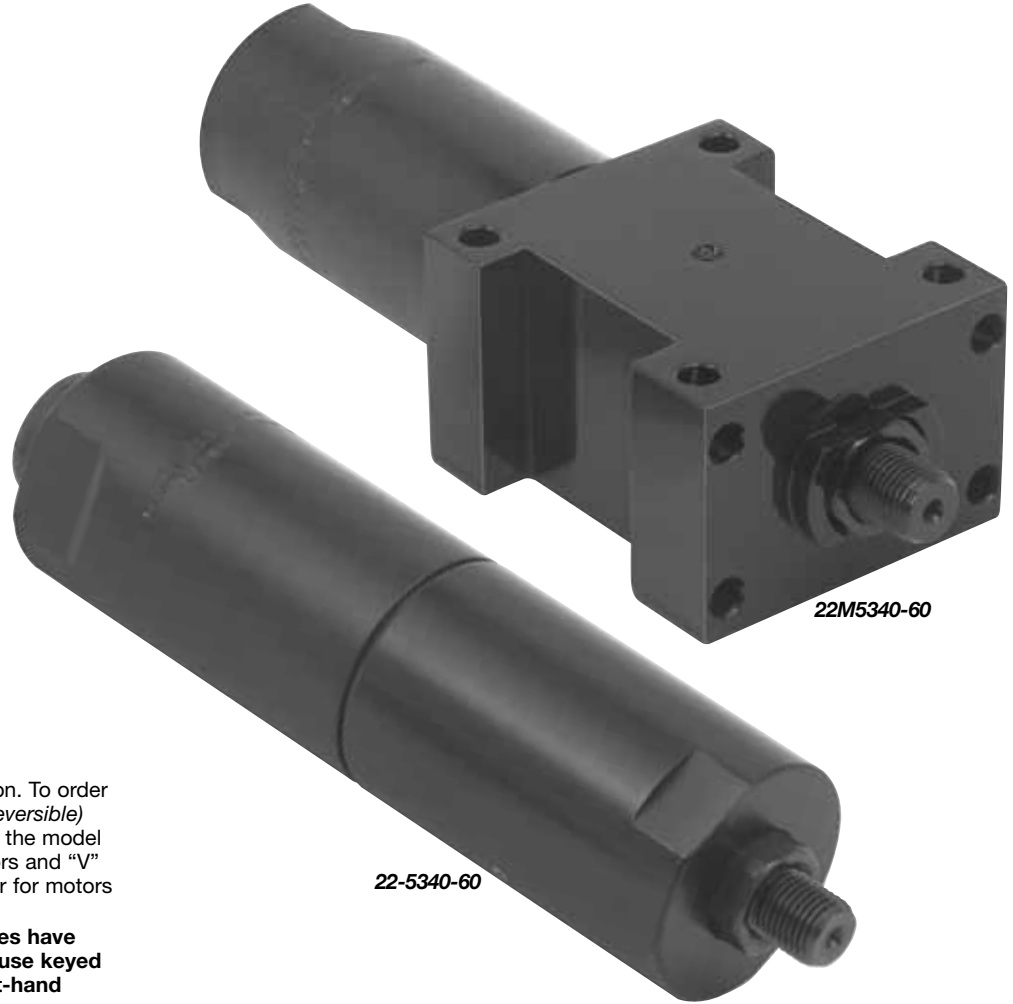

Spindle Rotation

All models are right-hand rotation. To order left-hand rotation models (*not reversible*) substitute “D” for the first “-” in the model number for round housing motors and “V” for the “M” in the model number for motors with flange and base mounting.

IMPORTANT: Threaded spindles have right-hand threads; therefore use keyed shaft models only (-50) for left-hand rotation.

Model Number*	RPM		Stall Torque		Weight		Gear Ratio	Length (page 11)	
	at Max. hp	Free Speed	ft lbs.	Nm	lbs.	kg		Overall (A) in.	Pilot (B) in.

Round Housing – 1/2” Diameter Keyed Spindle

22-5040-50	215	430	41.2	55.83	4.1	1.86	50.4:1	7.94	.25
22-5041-50	320	640	28.4	38.48	4.1	1.86	34.8:1	7.94	.25
22-5042-50	470	940	19.6	26.56	4.1	1.86	24:1	7.94	.25
22-5340-50	1600	3200	5.8	7.86	3.1	1.41	7.1:1	6.19	.25
22-5440-50	2350	4700	4.0	5.42	3.1	1.41	4.9:1	6.19	.25
22-5940-50	11500	23000	0.8	1.08	2.5	1.13	—	4.38	.63

Flange and Base Mounting – 1/2” Diameter Keyed Spindle

22M5042-50	470	940	19.6	26.56	5.0	2.27	24:1	7.94	.25
22M5340-50	1600	3200	5.8	7.86	4.0	1.81	7.1:1	6.19	.25
22M5440-50	2350	4700	4.0	5.42	4.0	1.81	4.9:1	6.19	.25
22M5940-50	11500	23000	.8	1.08	3.4	1.54	—	4.38	.63

General:

Air Inlet: 1/4” NPT – Side and rear
Air consumption: 29 cfm (.82 m³/min)
All tools performance rated @ 90psi (620 kPa) air pressure.

*Optional Terminations:

Replace -50 in model number with the desired termination when ordering.

- 38 0”-1/4” Capacity Drill Chuck (5000 RPM or less)
- 51 1/16”-3/8” Capacity Drill Chuck (5000 RPM or less)
- 53 5/64”-1/2” Capacity Drill Chuck (5000 RPM or less)
- 60 1/2”-20 Threaded Spindle
- 01 Series 200 Collet Chuck (for milling and routing)
- 62 Series “K” Collet Chuck (for milling and routing)

Standard Equipment:

Hex socket screw provided for closure of unused inlet. Flush fitting for lubrication of gears. Wrench for threaded spindle and collet chuck models. 1/4” collet included with series 200 & “K” collet chuck.

Optional Equipment:

Exhaust mufflers, remote-exhaust hoses, air intake hoses, spindle adapters and filter-lubricator-regulators available at extra cost. Any series 200 and “K” collet may be substituted at no additional cost.

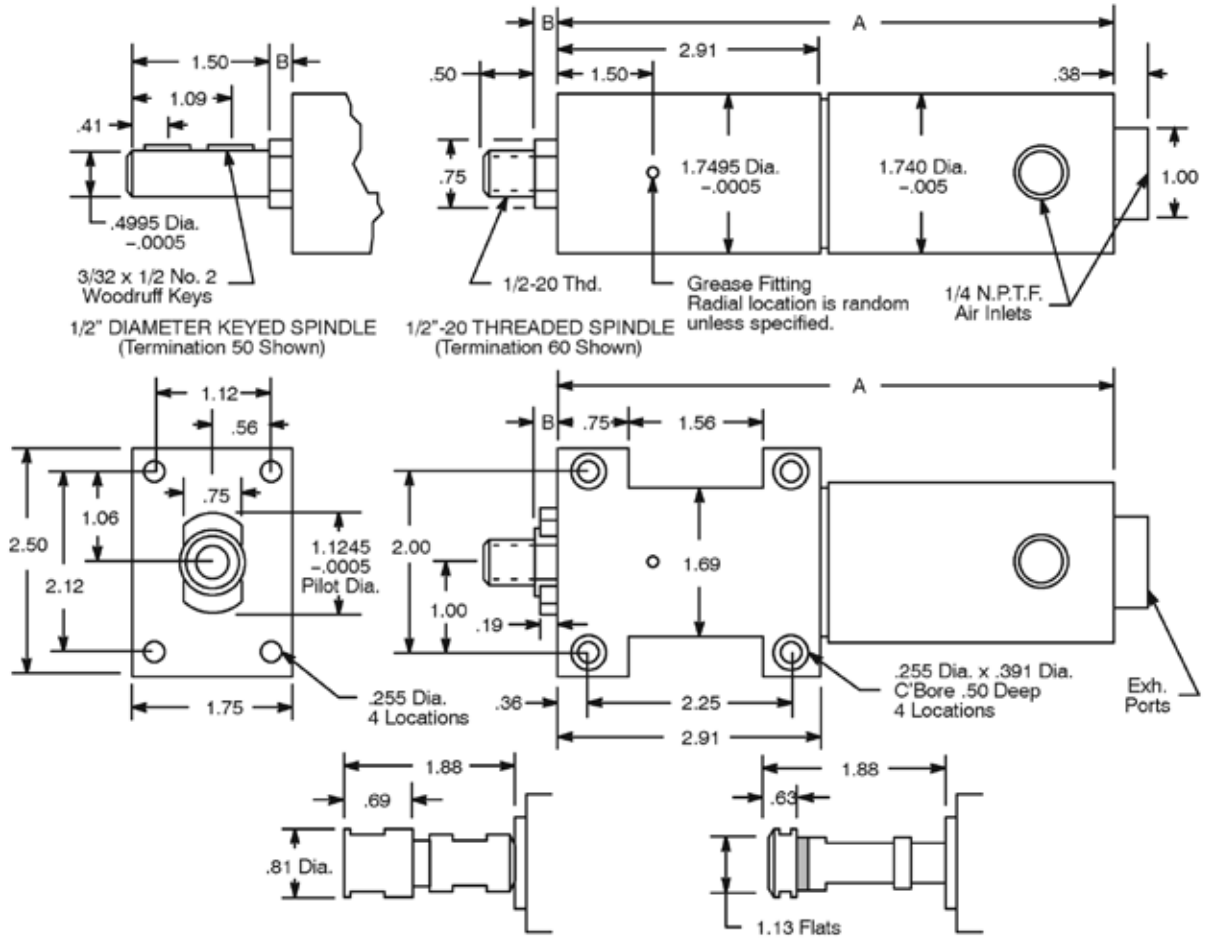

SERIES 200 COLLET CHUCK (Termination 01 Shown)

SERIES K COLLET CHUCK (Termination 62 Shown)

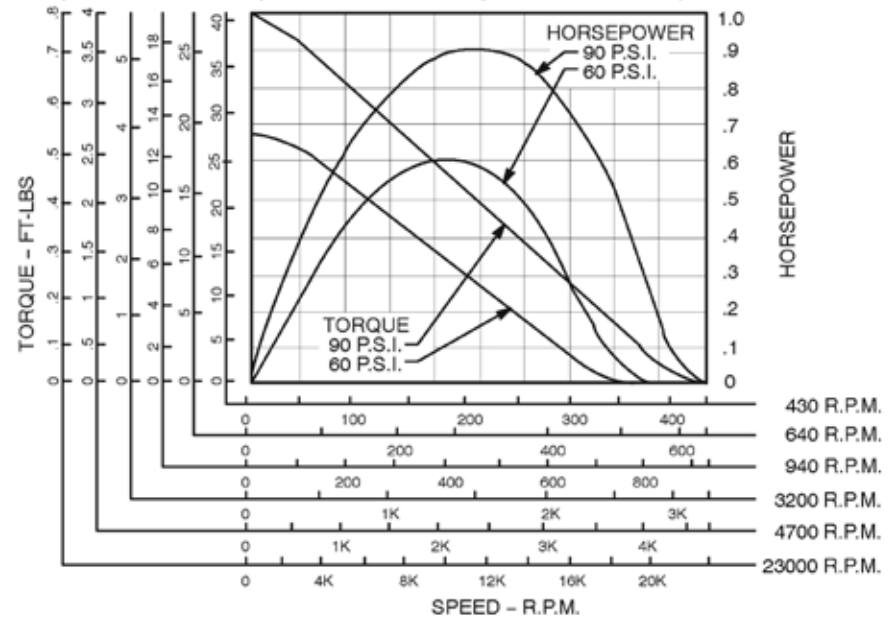

Important:

A 3/8" I.D. air inlet hose may be used for runs up to 10'. For longer runs, use 1/2" I.D. hoses. When remote-exhaust hose is used, the portion of air inlet hose inserted into the exhaust hose should not exceed 3/8" I.D. (approx. .650" O.D.). Planetary gears should be greased after every 250 hours with gear grease # 45-0983, or equivalent. For Filters, Regulators and Lubricators refer to pgs. 60-61.

If air line connector is used, install at end of hose away from the tool.

Concentricity:

On motors with round housings, concentricity of spindle to O.D. of housing is .003 TIR.



22 Series

- Maximum Power
0.9 hp
0.67 kW
- Torque Range
5.8 – 41.2 ft. lbs.
7.86 – 55.83 Nm
- Non-Reversible
- Side Exhaust



Spindle Rotation

All models are right-hand rotation. To order left-hand rotation models (*not reversible*) substitute “D” for the first “-” in the model number for round housing motors and “V” for the “M” in the model number for motors with flange and base mounting.

IMPORTANT: Threaded spindles have right-hand threads; therefore use keyed shaft models only (-50) for left-hand rotation.

Model Number*	RPM		Stall Torque		Weight		Gear Ratio	Length (page 13)		
	at Max. hp	Free Speed	ft lbs.	Nm	lbs.	kg		Overall (A) in.	Pilot (B) in.	
Round Housing – 1/2” Diameter Keyed Spindle										
22-5000-50	215	430	41.2	55.83	4.2	1.91	50.4:1	7.94	.25	
22-5002-50	470	940	19.6	26.56	4.2	1.91	24:1	7.94	.25	
Flange and Base Mounting – 1/2” Diameter Keyed Spindle										
22M5000-50	215	430	41.2	55.83	5.1	2.31	50.4:1	7.94	.25	
22M5001-50	320	640	28.4	38.48	5.1	2.31	3.48:1	7.94	.25	
22M5002-50	470	940	19.6	26.56	5.1	2.31	24:1	7.94	.25	
22M5300-50	1600	3200	5.8	7.86	4.1	1.86	7.1:1	6.19	.25	

General:

Air Inlet: 1/4” NPT – Side and rear
Air consumption: 29 cfm (.82 m³/min)
All tools performance rated @ 90psi (620 kPa) air pressure.

*Optional Terminations:

Replace -50 in model number with the desired termination when ordering.

- 38 0”-1/4” Capacity Drill Chuck (5000 RPM or less)
- 51 1/16”-3/8” Capacity Drill Chuck (5000 RPM or less)
- 53 5/64”-1/2” Capacity Drill Chuck (5000 RPM or less)
- 60 1/2”-20 Threaded Spindle
- 01 Series 200 Collet Chuck (for milling and routing)
- 62 Series “K” Collet Chuck (for milling and routing)

Standard Equipment:

Hex socket screw provided for closure of unused inlet. Flush fitting for lubrication of gears. Wrench for threaded spindle and collet chuck models. 1/4” collet included with series 200 & “K” collet chuck.

Optional Equipment:

Exhaust mufflers, remote-exhaust hoses, air intake hoses, spindle adapters and filter-lubricator-regulators available at extra cost. Any series 200 and “K” collet may be substituted at no additional cost.

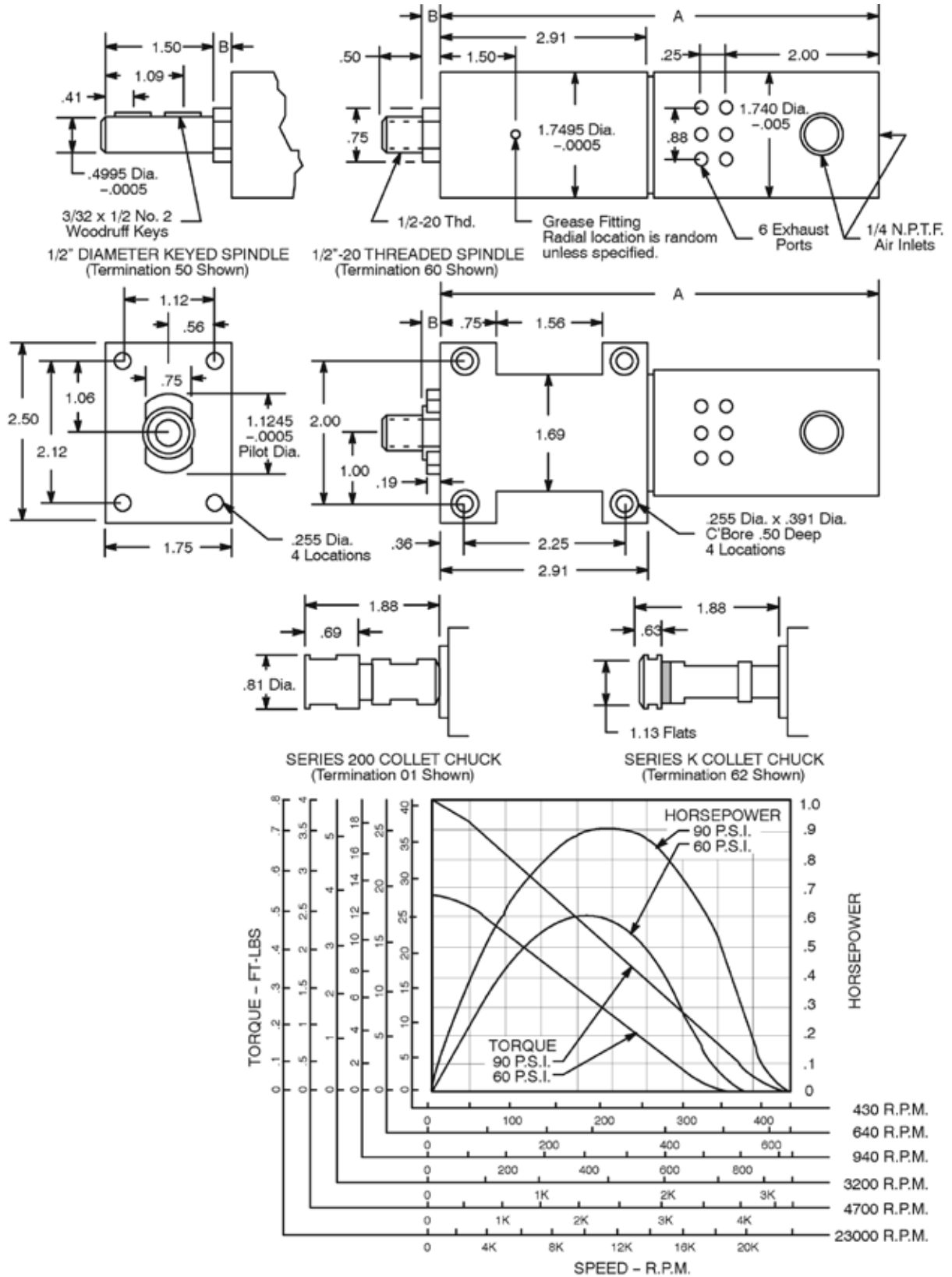

Important:

A 3/8" I.D. air inlet hose may be used for runs up to 10'. For longer runs, use 1/2" I.D. hoses. Planetary gears should be greased after every 250 hours with gear grease # 45-0983, or equivalent. For Filters, Regulators and Lubricators refer to page 64. If air line connector is used, install at end of hose away from the tool.

Concentricity:

On motors with round housings, concentricity of spindle to O.D. of housing is .003 TIR.

Cleco®

22 Series

- Maximum Power
0.7 hp
0.52 kW
- Torque Range
0.6 – 28.4 ft. lbs.
0.81 – 38.48 Nm
- Reversible
- Side Exhaust



Model Number*	RPM		Stall Torque		Weight		Gear Ratio	Length (page 15)		
	at Max. hp	Free Speed	ft lbs.	Nm	lbs.	kg		Overall (A) in.	Pilot (B) in.	
Round Housing – 1/2" Diameter Keyed Spindle										
22-5070-50	165	330	28.4	38.48	2.75	1.25	50.4:1	7.88	.25	
22-5370-50	1750	3500	2.8	3.79	2.06	0.93	4.9:1	6.16	.25	
Flange and Base Mounting – 1/2" Diameter Keyed Spindle										
22M5070-50	165	330	28.4	38.48	3.06	1.39	50.4:1	7.88	.25	
22M5071-50	250	500	19.6	26.56	3.06	1.39	3.48:1	7.88	.25	
22M5072-50	350	700	13.5	18.29	3.06	1.39	24:1	7.88	.25	
22M5270-50	1200	2400	4.0	5.42	2.38	1.08	7.1:1	6.16	.25	

General:

Air Inlet: 1/4" NPT – Side and rear
 Air consumption: 29 cfm (.82 m³/min)
 All tools performance rated @ 90psi (620 kPa) air pressure.

***Optional Terminations:**

Replace -50 in model number with the desired termination when ordering.

- 38 0"-1/4" Capacity Drill Chuck (5000 RPM or less)
- 51 1/16"-3/8" Capacity Drill Chuck (5000 RPM or less)
- 53 5/64"-1/2" Capacity Drill Chuck (5000 RPM or less)
- 60 1/2"-20 Threaded Spindle
- 01 Series 200 Collet Chuck (for milling and routing)
- 62 Series "K" Collet Chuck (for milling and routing)

Standard Equipment:

Hex socket screw provided for closure of unused inlet. Flush fitting for lubrication of gears. Wrench for threaded spindle and collet chuck models. 1/4" collet included with series 200 & "K" collet chuck.

Optional Equipment:

Exhaust mufflers, remote-exhaust hoses, air intake hoses, spindle adapters and filter-lubricator-regulators available at extra cost. Any series 200 and "K" collet may be substituted at no additional cost.

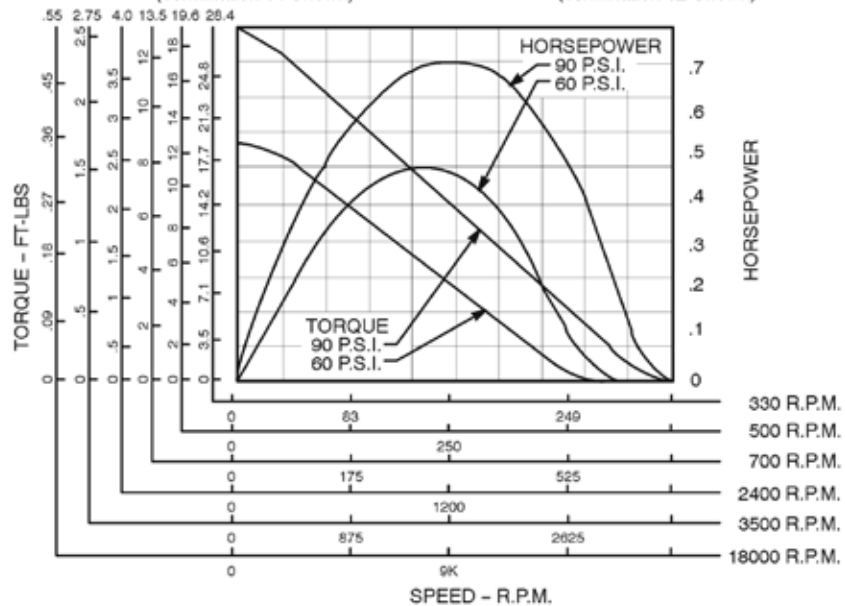
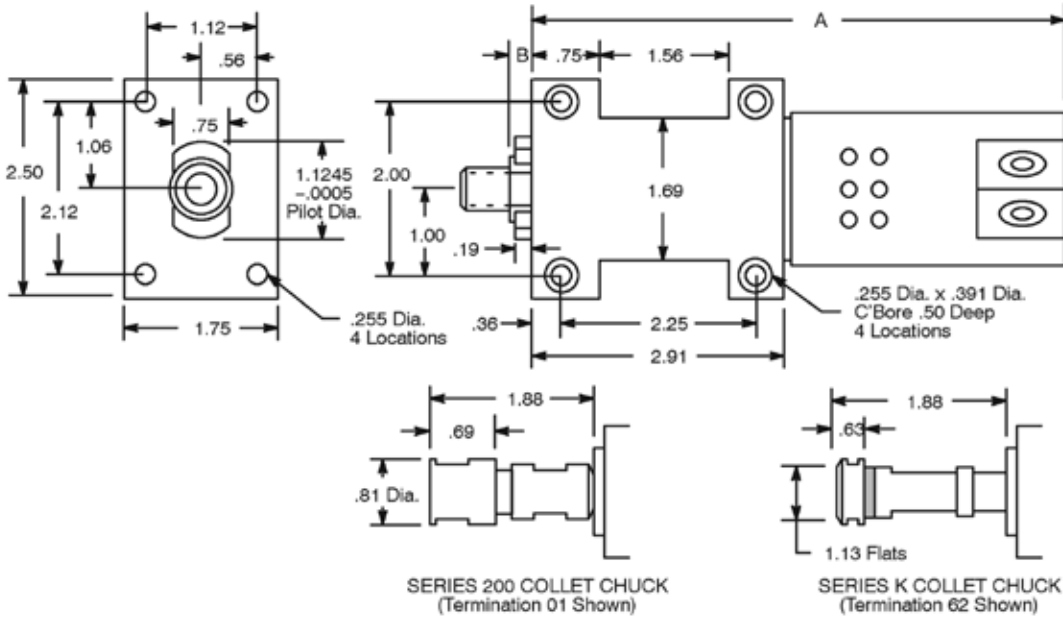
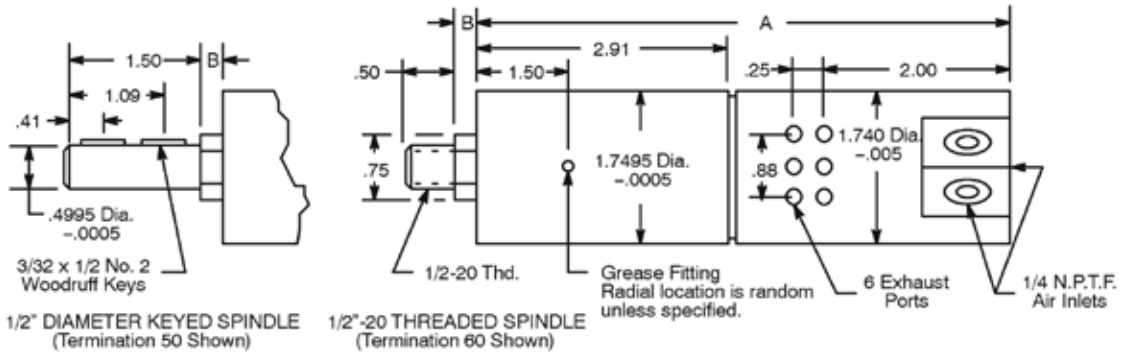

Important:

A 3/8" I.D. air inlet hose may be used for runs up to 10'. For longer runs, use 1/2" I.D. hoses. Planetary gears should be greased after every 250 hours with gear grease # 45-0983, or equivalent. For Filters, Regulators and Lubricators refer to page 64. If air line connector is used, install at end of hose away from the tool.

Concentricity:

On motors with round housings, concentricity of spindle to O.D. of housing is .003 TIR.

Note:

Spindles with 1/2"-20 thread are equipped with 1/4"-28 internal threaded jam screw. This will prevent sprockets or pulleys from unthreading in reverse direction.

Optional Equipment for 21 & 22 Series Motors

Exhaust Muffler

With this Exhaust Muffler, the noise level is approximately 85 dBA. It is recommended that a motor always be used with this muffler, unless provision is made in the mounting structure, by the user, for an exhaust cavity to provide noise attenuation.

Use Exhaust Muffler 14-1117 on 21 Series side exhaust motors and 14-2110 on 22 series side exhaust motors.



14-1117



14-2110

Muffler with Remote-Exhaust Hose

Remote-exhaust Hose 45-2000 (specify length desired) can be attached to the muffler with Hose Clamp 45-2126 to provide remote exhaust and additional quieting. (4' length reduces noise level to 80 dBA)

Remote-Exhaust Hose (Rear Exhaust Models)

Standard Hose Lengths	
Part Number	Length (ft.)
45-2003	3
45-2004	4
45-2006	6
45-2008	8
45-2010	10
45-2012	12
45-2016	16
45-2020	20
45-2025	25



45-2003

Dual Hose Adapter

Adapters for rear exhaust non-reversible models for separate inlet and exhaust hoses. Provides piped exhaust for clean of white room applications, power plants, etc.

Part Number: 14-2263
 Motor Series: 21 & 22
 Inlet Size: 1/4" NPT
 Exhaust Size: 3/8" NPT



14-2263



204

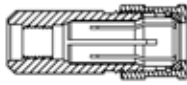

304

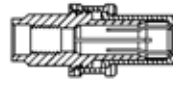

120

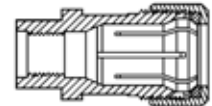

Part Number	Size	Capacity	
		min.	max.
Termination 01 – Series 200 Collets			
204	1/8"	3/32"	1/8"
205	5/32"	1/8"	5/32"
206	3/16"	5/32"	3/16"
207	7/32"	3/16"	7/32"
208	1/4"	7/32"	1/4"
209	9/32"	1/4"	9/32"
210	5/16"	9/32"	5/16"
211	11/32"	5/16"	11/32"
212	3/8"	11/32"	3/8"
213	6mm	—	—
216	6mm	—	—

Part Number	Size	Capacity	
		min.	max.
Termination 36 – Series 300 Collets			
301	3/64"	1/64"	3/64"
302	5/64"	3/64"	5/64"
303	3/32"	1/16"	3/32"
304	1/8"	3/32"	1/8"
305	5/32"	1/8"	5/32"
306	3/16"	5/32"	3/16"
307	7/32"	3/16"	7/32"
308	1/4"	7/32"	1/4"
310	6mm	—	—
311	3mm	—	—

Part Number	Size	Capacity	
		min.	max.
Termination 62 – Series K Collets			
120	1/8"	3/32"	1/8"
121	3/16"	5/32"	3/16"
122	1/4"	7/32"	1/4"
123	5/16"	9/32"	5/16"
124	3/8"	11/32"	3/8"
125	7/16"	13/32"	7/16"
126	1/2"	15/32"	1/2"
127	9/16"	17/32"	9/16"
134	8mm	—	—
135	10mm	—	—

Hose Line Lubricator

45-0201 – 1/4" NPTF
45-0301 – 3/8" NPTF

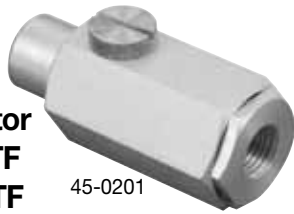

Mounts in Hose Line. One ounce reservoir good for average 8-hour shift. Use in locations where it is inconvenient to use a standard air line lubricator.

Push Pull Sleeve Valve

14-2209



Air inlet 1/4" female NPT; outlet is 1/4" male NPTF; stainless steel sleeve body; oil resistant O-rings.

Air Pressure Needle Gauge

14-0612

Used for checking air pressure in the air hose close to tool, while tool is running. Furnished with metal guard and carrying case.



Push Type Grease Gun

45-0982

For gear lubrication, for small flush type fittings. Can be operated with one hand. **45-0983 GEAR GREASE** for lubrication of planetary gearing.



Hose line filter

45-0211

Contains a replaceable filter cartridge. Will not remove water. To be used where it is inconvenient to use standard air line filter. Filter complete with cartridge No. 45-0211. Replacement cartridge only, No. 45-0212.

Flexible air hose

No.	Hose I.D.	Length	Fittings
45-1307	3/16	7	1/4 x 1/8
45-1408	1/4	8	1/4 x 1/4
45-1508	5/16	8	1/4 x 1/4
45-1610	3/8	10	3/8 x 3/8
45-1812	1/2	12	1/2 x 1/2
45-1825	1/2	25	1/2 x 1/2



Lubricating oil

45-0918 - Qt.
45-0919 - Gal.

An excellent lubricant for pneumatic tools, non-tacky, non-gumming. Use full strength in automatic lubricators.



45-0918



Gear grease

45-0992
14-1/2 oz. cartridge

Excellent grease for hi-speed gears after every 8 hours of operation.

Quick Disconnect Fittings				
Type of Fitting	Thd	Nominal Size		
		1/4	3/8	1/2
Male Pipe Threads				
Coupler	1/8	45-0710	—	—
Coupler	1/4	45-0711	45-0713	—
Coupler	3/8	45-0712	—	—
Coupler	1/2	—	—	45-0717
Female Pipe Threads				
Coupler	3/8	45-0732	45-0734	45-0736
Male Pipe Threads				
Nipple	1/8	45-0720	—	—
Nipple	1/4	—	45-0724	—
Nipple	3/8	45-0722	45-0725	45-0726
Nipple	1/2	—	—	45-0727
Female Pipe Threads				
Nipple	1/4	—	45-0744	—
Nipple	3/8	45-0742	45-0745	45-0746
Nipple	1/2	—	—	45-0747
With Hose Barbs				
Nipple	1/4	45-0748	—	—
Nipple	1/2	—	—	45-0753





21MF Series

- Maximum Power
0.3 hp
0.22 kW
- Torque Range
0.24 – 11.3 ft. lbs.
0.3 – 15.3 Nm
- Non-Reversible
- Side Exhaust
- Threaded or Keyed Spindle



21MFN900M

Speed Code	"A" Dim.
Code 0, 1, 2 & 3	5.69
Code 4	6.06
Code 5, 6 & 7	6.75

Speed code refers to last digit in model number.

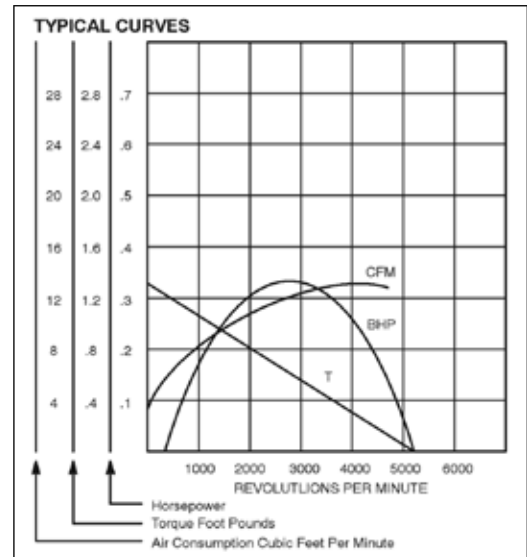
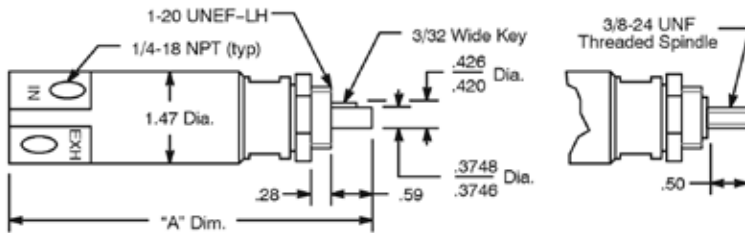

Model Number		RPM		Stall Torque		Weight		Gear Ratio
3/8" Threaded	3/8" Keyed	at Max. hp	Free Speed	ft lbs.	Nm	lbs.	kg	

Spindle – RH Rotation

21MFN900M	21MFN910M	12000	24000	.24	.3	1.7	.771	—
21MFN901M	21MFN911M	2375	4750	1.30	1.8	1.7	.771	5.0:1
21MFN902M	21MFN912M	1750	3500	1.70	2.3	1.7	.771	6.8:1
21MFN903M		1400	2800	2.10	2.8	1.7	.771	8.6:1
	21MFN914M	1050	2100	2.80	3.8	1.8	.816	11.4:1
	21MFN915M	450	900	6.90	9.4	2.0	.907	26.6:1
21MFN906M	21MFN916M	325	650	9.30	12.6	2.0	.907	36.9:1
21MFN907M	21MFN917M	250	500	11.30	15.3	2.0	.907	48.0:1

General:

Air Inlet: 1/4" NPT
Air consumption: 12 cfm (.34 m³/min)
Offset (Side-to-Center) – 47/64"
Achieves full speed within a half revolution

All tools performance rated @ 90psi (620 kPa) air pressure.

Standard Equipment:
1015869 Muffler

21MR Series

- Maximum Power
0.25 hp
0.19 kW
- Torque Range
1.6 – 10.0 ft. lbs.
2.2 – 13.6 Nm
- Reversible
- Side Exhaust
- Keyed Spindle



21MRR912M

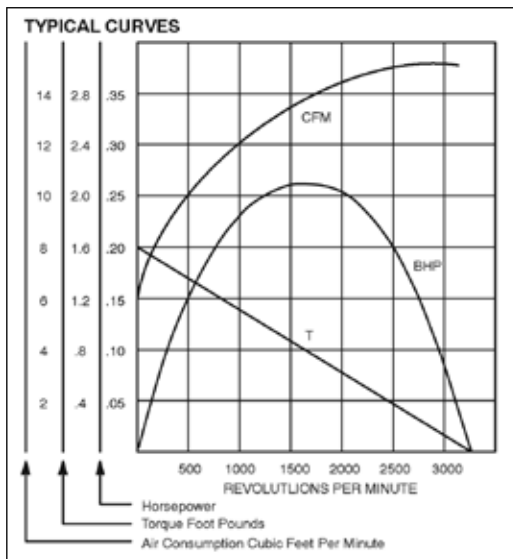

Speed Code	"A" Dim.
Code 1, 2 & 3	6.50
Code 4	6.75
Code 5, 6 & 7	7.56

Speed code refers to last digit in model number.

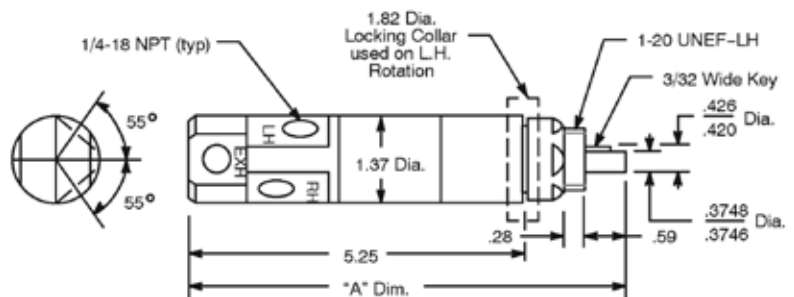

Model Number	RPM		Stall Torque		Weight		Gear Ratio
	at Max. hp	Free Speed	ft lbs.	Nm	lbs.	kg	

3/8" Keyed Spindle

21MRR912M	1500	3000	1.60	2.2	1.9	.862	6.8:1
21MRR913M	1225	2450	1.90	2.6	1.9	.862	8.6:1
21MRR914M	900	1800	2.50	3.4	2.0	.907	11.4:1
21MRR917M	200	400	10.00	13.6	2.2	.998	48.0:1

General:

Air Inlet: 1/4" NPT
 Air consumption: 12 cfm (.34 m³/min)
 Offset (Side-to-Center) – 47/64"
 Achieves full speed within a half revolution

Can be reversed instantaneously and continuously.
 All tools performance rated @ 90psi (620 kPa) air pressure.

Standard Equipment:
 1015748 Muffler

Rotary Vane

Cleco®

31MF Series

- Maximum Power
0.5 hp
0.37 kW
- Torque Range
0.5 – 23.6 ft. lbs.
0.68 – 32 Nm
- Non-Reversible
- Side Exhaust
- Threaded or Keyed Spindle



31MFN900M

Speed Code	"A" Dim.	"B" Dim.
Code 0, 1, 2 & 3	6.18	6.06
Code 4	6.87	6.75
Code 5, 6 & 7	7.56	7.44

Speed code refers to last digit in model number.

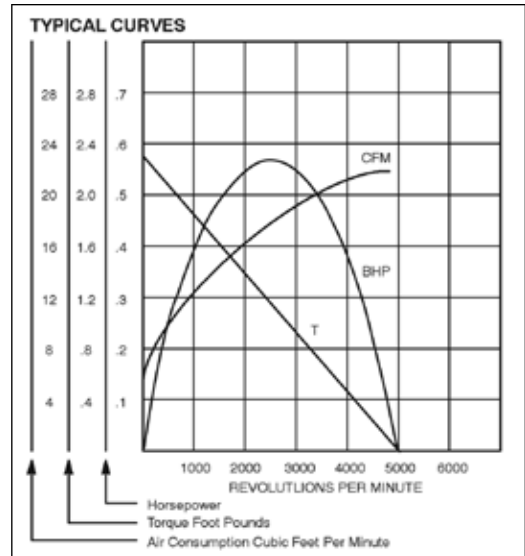
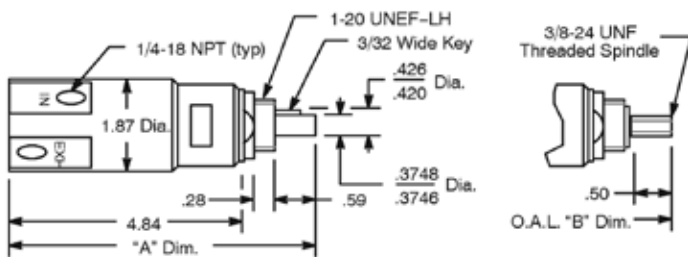

Model Number		RPM		Stall Torque		Weight		Gear Ratio
3/8" Threaded	3/8" Keyed	at Max. hp	Free Speed	ft lbs.	Nm	lbs.	kg	

Spindle – RH Rotation

31MFN900M	31MFN910M	10000	20000	0.5	0.68	2.7	1.225	—
31MFN901M		2500	5000	2.2	3.00	2.7	1.225	4.0:1
31MFN902M	31MFN912M	1500	3000	3.5	4.70	2.7	1.225	6.44:1
31MFN903M		925	1850	5.9	8.00	2.7	1.225	10.8:1
31MFN904M		700	1400	7.1	9.60	2.8	1.270	14.28:1
31MFN905M	31MFN915M	550	1100	8.8	11.90	3.1	1.406	16.0:1
31MFN906M	31MFN916M	375	750	14.1	19.10	3.1	1.406	25.73:1
31MFN907M	31MFN917M	225	450	23.6	32.00	3.1	1.406	43.06:1

General:

Air Inlet: 1/4" NPT
Air consumption: 18 cfm (.51 m³/min)
Offset (Side-to-Center) – 15/16"

Achieves full speed within a half revolution

All tools performance rated @ 90psi (620 kPa) air pressure.

Standard Equipment:

1015869 Muffler



31MRR911M

31MR Series

- Maximum Power
0.3 hp
0.22 kW
- Torque Range
2 – 21.6 ft. lbs.
2.7 – 29.3 Nm
- Reversible
- Side Exhaust
- Keyed Spindle

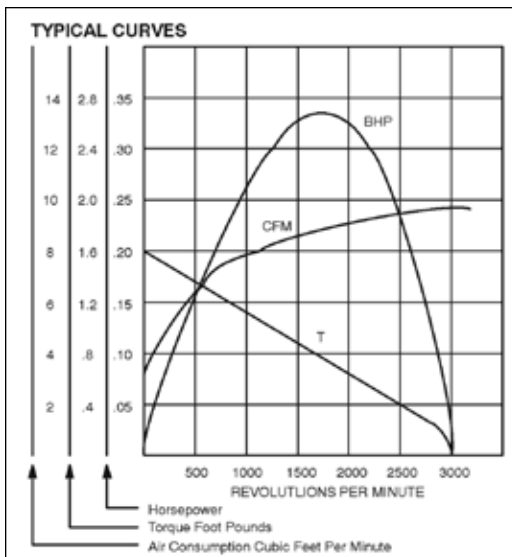

Speed Code	"A" Dim.
Code 1, 2 & 3	6.93
Code 4	7.62
Code 5, 6 & 7	8.31

Speed code refers to last digit in model number.

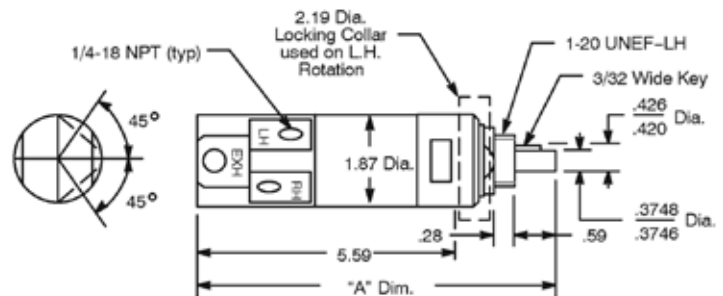

Model Number	RPM		Stall Torque		Weight		Gear Ratio
	at Max. hp	Free Speed	ft lbs.	Nm	lbs.	kg	

3/8" Keyed Spindle

31MRR911M	1750	3500	2.0	2.7	3.5	1.588	4.0:1
31MRR912M	1075	2150	3.2	4.3	3.5	1.588	6.44:1
31MRR914M	500	1000	6.5	8.8	3.6	1.633	14.28:1
31MRR916M	250	500	12.8	17.4	3.8	1.723	25.73:1
31MRR917M	150	300	21.6	29.3	3.8	1.723	43.06:1

General:

Air Inlet: 1/4" NPT
 Air consumption: 12 cfm (.34 m³/min)
 Offset (Side-to-Center) – 47/64"
 Achieves full speed within a half revolution

Can be reversed instantaneously and continuously.
 All tools performance rated @ 90psi (620 kPa) air pressure.
Standard Equipment:
 1015748 Muffler

Rotary Vane

Cleco®

41MF Series

- Maximum Power
0.75 hp
0.56 kW
- Torque Range
2.8 – 37.8 ft. lbs.
3.8 – 51.3 Nm
- Non-Reversible
- Side Exhaust
- Threaded or Keyed Spindle



41MFN901M

Speed Code	"A" Dim.	"B" Dim.
Code 0, 1, 2 & 3	7.73	6.98
Code 4	8.23	7.48
Code 5, 6 & 7	9.23	8.48

Speed code refers to last digit in model number.

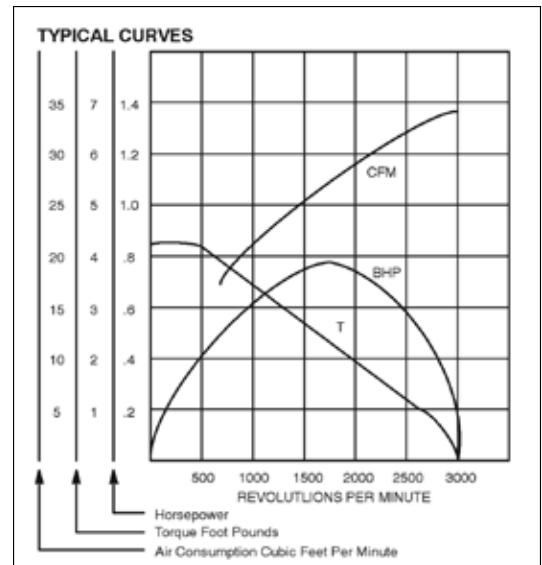
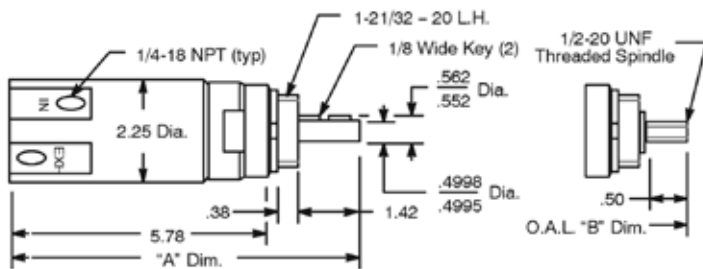

Model Number		RPM		Stall Torque		Weight		Gear Ratio
1/2" Threaded	1/2" Keyed	at Max. hp	Free Speed	ft lbs.	Nm	lbs.	kg	

Spindle – RH Rotation

41MFN901M	41MFN911M	2250	4500	2.8	3.80	4.9	2.222	4.0:1
41MFN902M	41MFN912M	1500	3000	4.2	5.70	4.9	2.222	6.0:1
41MFN905M	41MFN915M	500	1000	11.2	15.20	5.4	2.450	16.0:1
	41MFN916M	363	725	16.8	22.80	5.4	2.450	24.7:1
41MFN907M	41MFN917M	250	500	25.2	34.20	5.4	2.450	36.0:1
41MFN908M	41MFN918M	165	330	37.8	51.30	5.4	2.450	54.5:1

General:

Air Inlet: 1/4" NPT
Air consumption: 27 cfm (.76 m³/min)
Offset (side-to-center) – 1-7/32"

Achieves full speed within a half revolution

All tools performance rated @ 90psi (620 kPa) air pressure.

Standard Equipment:

1015869 Muffler



41MRR911M

41MR Series

- Maximum Power
0.6 hp
0.45 kW
- Torque Range
2.9 – 39.6 ft. lbs.
3.9 – 53.7 Nm
- Reversible
- Side Exhaust
- Keyed Spindle

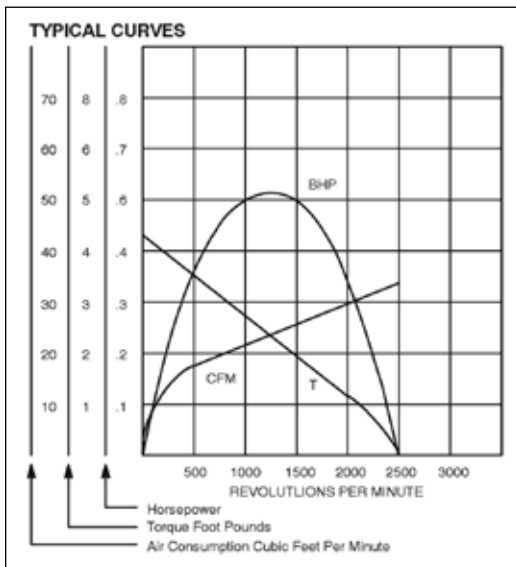

Speed Code	"A" Dim.
Code 1, 2 & 3	8.42
Code 4	8.92
Code 5, 6 & 7	9.92

Speed code refers to last digit in model number.

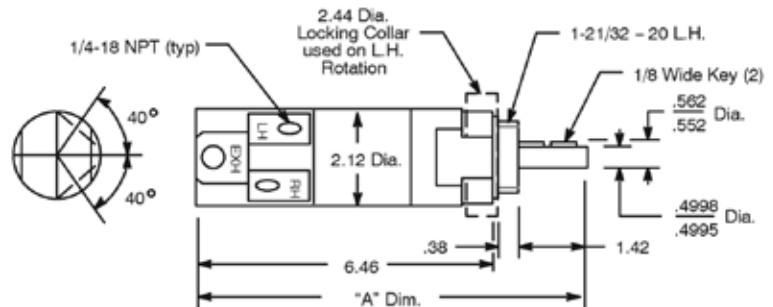

Model Number	RPM		Stall Torque		Weight		Gear Ratio
	at Max. hp	Free Speed	ft lbs.	Nm	lbs.	kg	

1/2" Keyed Spindle

41MRR911M	1875	3750	2.9	3.9	4.9	2.222	4.0:1
41MRR912M	1250	2500	4.4	6.0	4.9	2.222	6.0:1
41MRR914M	600	1200	9.1	12.3	4.9	2.222	12.37:1
41MRR915M	450	900	11.7	15.9	5.4	2.450	16.0:1
41MRR916M	313	625	17.6	23.9	5.4	2.450	24.7:1
41MRR917M	200	400	26.4	35.8	5.4	2.450	36.0:1
41MRR918M	138	275	39.6	53.7	5.4	2.450	54.5:1

General:

Air Inlet: 1/4" NPT
Air consumption: 25 cfm (.71 m³/min)
Offset (Side-to-Center) – 1-7/32"

Can be reversed instantaneously and continuously.
All tools performance rated @ 90psi (620 kPa) air pressure.

Standard Equipment:
1024078 Muffler

Cleco®

61MF Series

- Maximum Power
1.5 hp
1.12 kW
- Torque Range
6.9 – 110 ft. lbs.
9.4 – 149.2 Nm
- Non-Reversible
- Side Exhaust
- Threaded or Keyed Spindle



61MFN911M

Speed Code	"A" Dim.
Code 1 & 2	10.47
Code 3, 4 & 5	12.28

Speed code refers to last digit in model number.

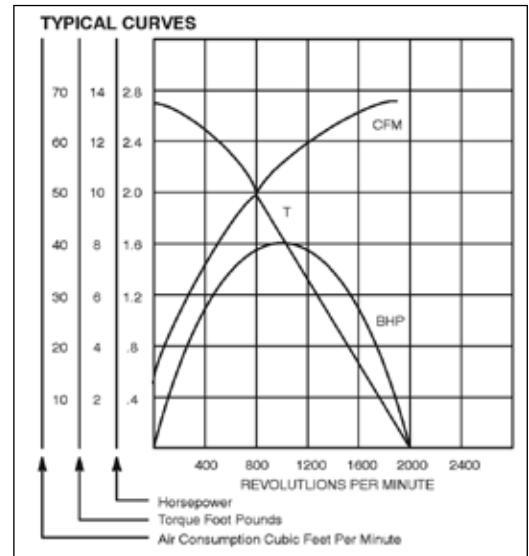
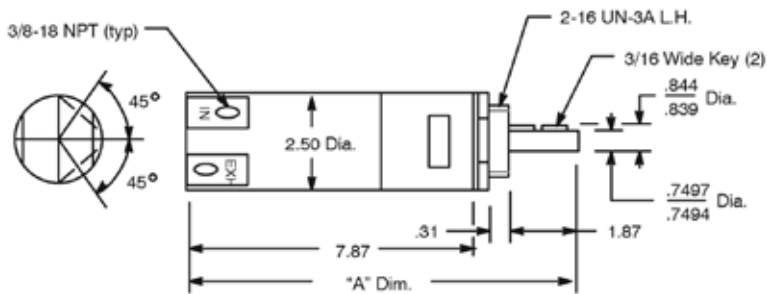

Model Number	RPM		Stall Torque		Weight		Gear Ratio
	at Max. hp	Free Speed	ft lbs.	Nm	lbs.	kg	

3/4" Keyed Spindle – RH Rotation

61MFN911M	1875	3700	6.9	9.4	8.0	3.629	4.0:1
61MFN912M	925	1850	13.6	18.4	8.0	3.629	8.14:1
61MFN913M	438	875	28.5	38.6	10.0	4.536	16.0:1
61MFN914M	225	450	56.0	75.9	10.0	4.536	32.57:1
61MFN915M	113	225	110.0	149.2	10.0	4.536	66.3:1

General

Air Inlet: 3/8" NPT
Air consumption: 55 cfm (1.56 m³/min)
Offset (side-to-center) – 1-1/4"

Achieves full speed within a half revolution
All tools performance rated @ 90psi (620 kPa) air pressure.

Standard Equipment:
1015870 Muffler



61MRR912M

61MR Series

- Maximum Power
1.0 hp
0.75 kW
- Torque Range
5.2 – 83 ft. lbs.
7.1 – 112.5 Nm
- Reversible
- Side Exhaust
- Keyed Spindle

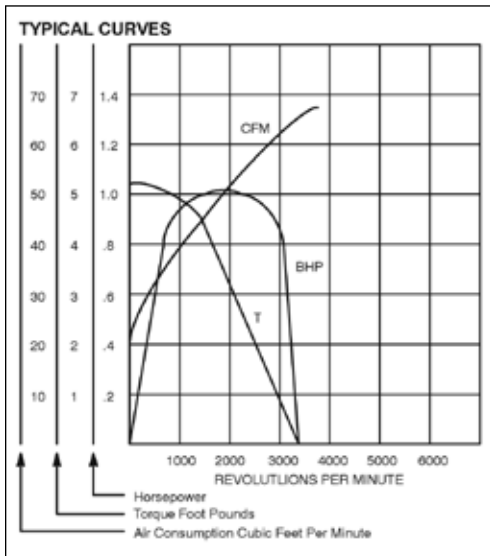

Speed Code	"A" Dim.
Code 1 & 2	10.70
Code 3, 4 & 5	12.59

Speed code refers to last digit in model number.

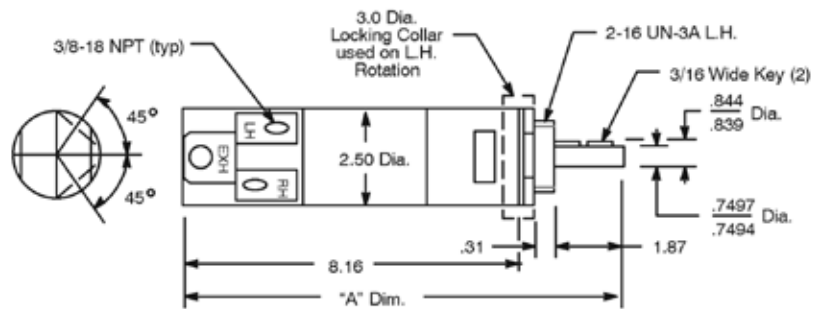

Model Number	RPM		Stall Torque		Weight		Gear Ratio
	at Max. hp	Free Speed	ft lbs.	Nm	lbs.	kg	

3/4" Keyed Spindle – RH Rotation

61MRR912M	850	1700	10.2	13.8	8.5	3.856	8.14:1
61MRR913M	413	825	21.5	29.2	10.5	4.763	16.0:1
61MRR914M	200	400	42.4	57.5	10.5	4.763	32.57:1
61MRR915M	100	200	83.0	112.5	10.5	4.763	66.3:1

General

Air Inlet: 3/8" NPT
Air consumption: 50 cfm (1.42 m³/min)
Offset (side-to-center) – 1-1/2"

Achieves full speed within a half revolution
All tools performance rated @ 90psi (620 kPa) air pressure.

Standard Equipment:
1015869 Muffler

Accessories for MF & MR Motors

Each air motor is supplied with its appropriate muffler. Choice of foot mount brackets or flange mount is provided as no-cost option with purchase of motor...if specified.

Muffler Identification

A muffler is furnished for the common exhaust outlet on all reversible motors. If a 4-way valve is preferred to facilitate reversing, a muffler will be needed on the exhaust outlet of the valve. Flow restriction through the valve and muffler must be minimized in order to maintain maximum power output. If a valve is not used, another muffler will be required on the inlet port not being utilized for optional inlet flow.



Part Number	Motor Series
Mufflers	
1015869	21MF
1015748	21MR
1015869	31MF
1015869	31MR
1015869	41MF
1024078	41MR
1015870	61MF
1015869	61MR
Foot Mounts	
1024282	21MF & 21MR
1024282	31MF & 31MR
1024283	41MF & 41MR
1024284	61MF & 61MR
Flange Mounts	
1024279	21MF & 21MR
1024279	31MF & 31MR
1024280	41MF & 41MR
1024281	61MF & 61MR

21 & 31 Series Foot Mount/Flange Mount Brackets

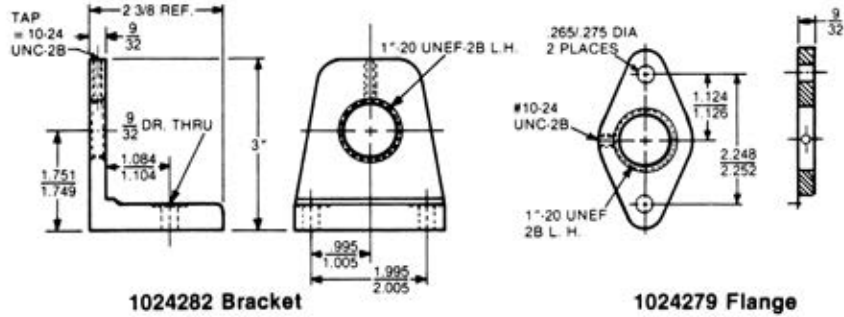

41 Series Foot Mount/Flange Mount Brackets

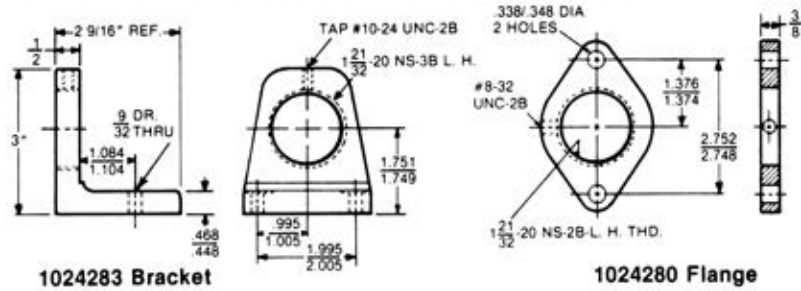

61 Series Foot Mount/Flange Mount Brackets

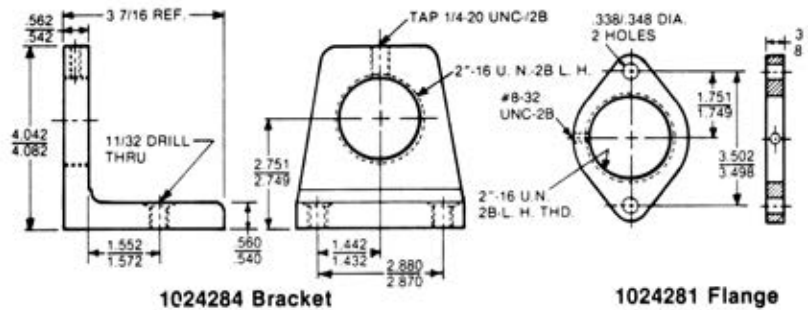

Cleco®

C3 Series

- Maximum Power
0.65 hp
0.48 kW
- Torque Range
1.5 – 30.5 ft. lbs.
2.0 – 42 Nm
- Non-Reversible
- Side Exhaust



C3N041M

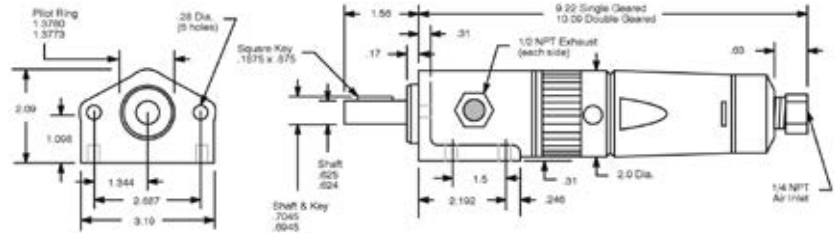
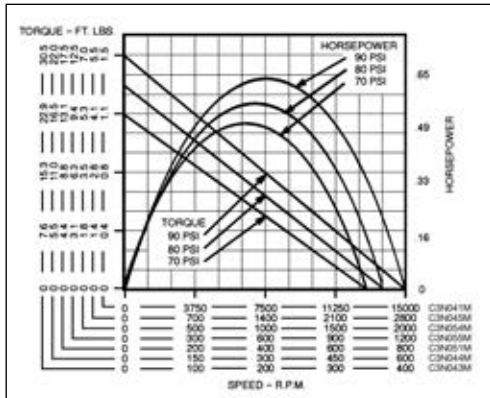

Model Number	RPM		Stall Torque		Weight		Gear Ratio	Max. Overhung Load @ Stall*	
	at Max. hp	Free Speed	ft lbs.	Nm	lbs.	kg		lbs.	kg

Foot and Flange Mounting – 5/8" Diameter Keyed Spindle

C3N041M	7500	15000	1.5	2.0	4.00	1.8	—	470	213
C3N045M	1400	2800	5.5	7.5	4.00	1.8	5:1	470	213
C3N054M	1000	2000	7.0	9.5	4.00	1.8	6.6:1	470	213
C3N055M	600	1200	12.5	17.0	4.50	2.0	12.56:1	470	213
C3N051M	400	800	17.5	24.0	4.50	2.0	17.74:1	470	213
C3N044M	300	600	22.0	30.0	4.50	2.0	23.47:1	470	213
C3N043M	200	400	30.5	42.0	4.50	2.0	33:1	470	213

*All models assume overhung load located at .94" (23.81mm) from face of motor.

General:

Air Inlet: 1/4" NPT
Air consumption: 28 cfm (.79 m³/min)
All tools performance rated @ 90psi (620 kPa) air pressure.

Standard Equipment:

Air strainer intake fitting. Foot and flange type mount.

Optional Equipment:

Speed Regulator – Part 504938
Pilot Ring – Part 30262
Lubricating Oil – Part 533485 (1 gallon)
Additional Accessories: Pages 64-65

C3 Series

- Maximum Power
0.45 hp
0.34 kW
- Torque Range
4.0 – 28 ft. lbs.
5.4 – 38 Nm
- Reversible
- Side Exhaust

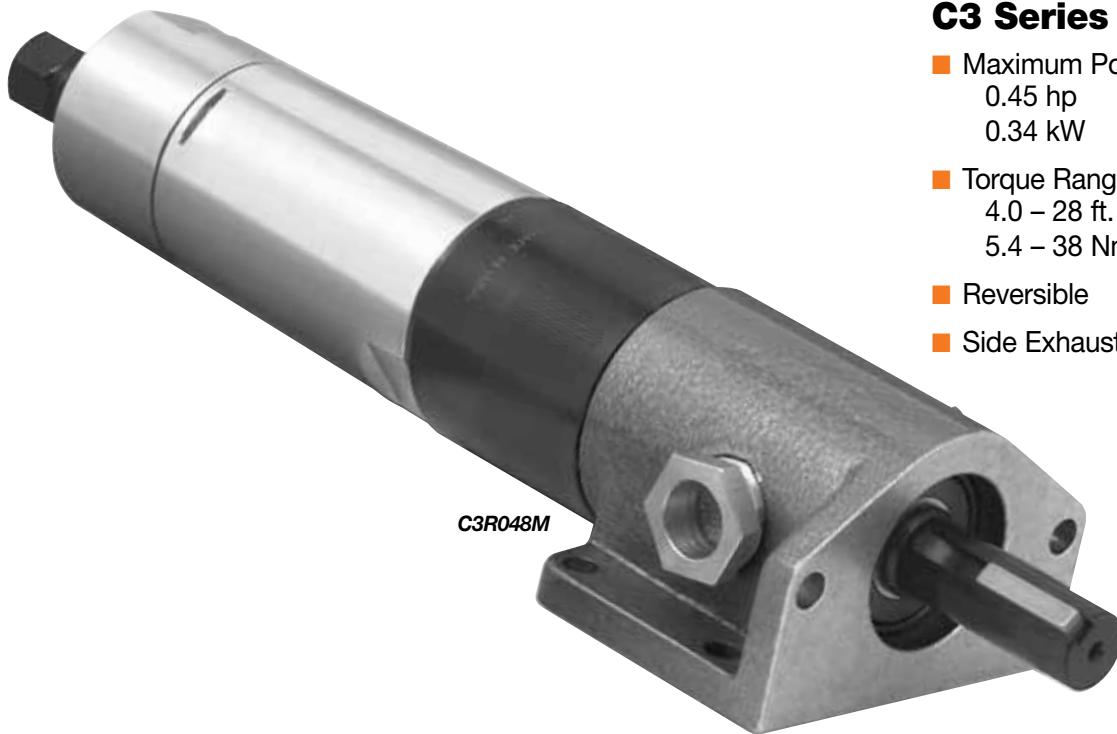

C3R048M

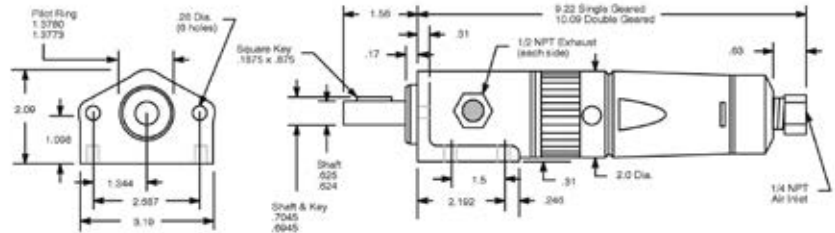
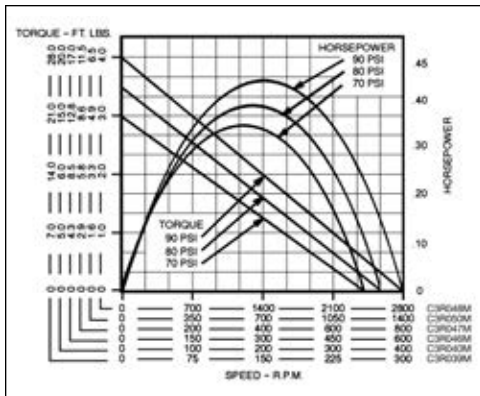

Model Number	RPM		Stall Torque		Weight		Gear Ratio	Max. Overhung Load @ Stall*	
	at Max. hp	Free Speed	ft lbs.	Nm	lbs.	kg		lbs.	kg
C3R048M	1400	2800	4.0	5.4	4.13	1.9	3.55:1	470	213
C3R050M	700	1400	6.5	8.8	4.13	1.9	6.6:1	470	213
C3R047M	400	800	11.5	15.6	4.63	2.1	12.56:1	470	213
C3R046M	300	600	17.0	23.0	4.63	2.1	17.74:1	470	213
C3R040M	200	400	20.0	27.0	4.63	2.1	23.47:1	470	213
C3R039M	150	300	28.0	38.0	4.63	2.1	33:1	470	213

Foot and Flange Mounting – 5/8" Diameter Keyed Spindle

C3R048M	1400	2800	4.0	5.4	4.13	1.9	3.55:1	470	213
C3R050M	700	1400	6.5	8.8	4.13	1.9	6.6:1	470	213
C3R047M	400	800	11.5	15.6	4.63	2.1	12.56:1	470	213
C3R046M	300	600	17.0	23.0	4.63	2.1	17.74:1	470	213
C3R040M	200	400	20.0	27.0	4.63	2.1	23.47:1	470	213
C3R039M	150	300	28.0	38.0	4.63	2.1	33:1	470	213

*All models assume overhung load located at .94" (23.81mm) from face of motor.

General:

Air Inlet: 1/4" NPT
Air consumption: 28 cfm (.79 m³/min)
All tools performance rated @ 90psi (620 kPa) air pressure.

Standard Equipment:

Air strainer intake fitting. Foot and flange type mount.

Optional Equipment:

Speed Regulator – Part 504938
Pilot Ring – Part 30262
Lubricating Oil – Part 533485 (1 gallon)
Additional Accessories: Pages 64-65

Cleco®

41 Series

- Maximum Power
1.25 hp
0.93 kW
- Torque Range
13 – 68.5 ft. lbs.
17.6 – 92.8 Nm
- Non-Reversible
- Side Exhaust



41N236M

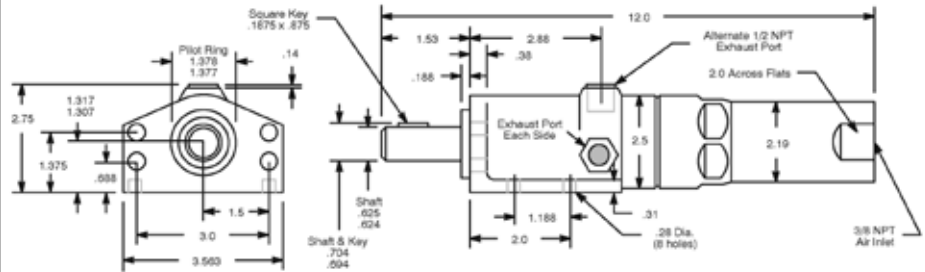
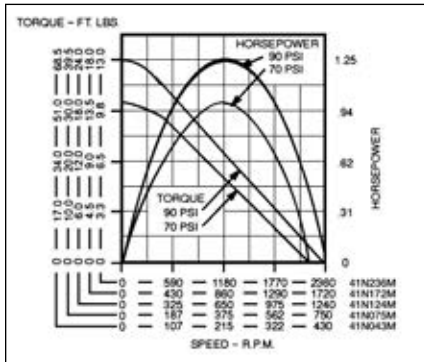

Model Number	RPM		Stall Torque		Weight		Gear Ratio	Max. Overhung Load @ Stall*	
	at Max. hp	Free Speed	ft lbs.	Nm	lbs.	kg		lbs.	kg

Foot and Flange Mounting – 5/8" Diameter Keyed Spindle

41N236M	1180	2360	13.0	17.6	6.25	2.84	7.2:1	600	272
41N172M	860	1720	18.0	24.4	6.25	2.84	9.86:1	600	272
41N124M	650	1240	24.0	32.5	6.25	2.84	13.7:1	600	272
41N075M	375	750	39.5	53.6	6.50	2.95	22.6:1	600	272
41N043M	215	430	68.5	92.8	6.50	2.95	39:1	600	272

*All models assume overhung load located at .94" (23.81mm) from face of motor.

General:

Air Inlet: 3/8" NPT

Air consumption: 40 cfm (1.13 m³/min)

All tools performance rated @ 90psi (620 kPa) air pressure.

Standard Equipment:

Air strainer intake fitting. Foot and flange type mount.

Optional Equipment:

Pilot Ring – Part 520886

Lubricating Oil – Part 533485 (1 gallon)

Additional Accessories: Pages 64-65

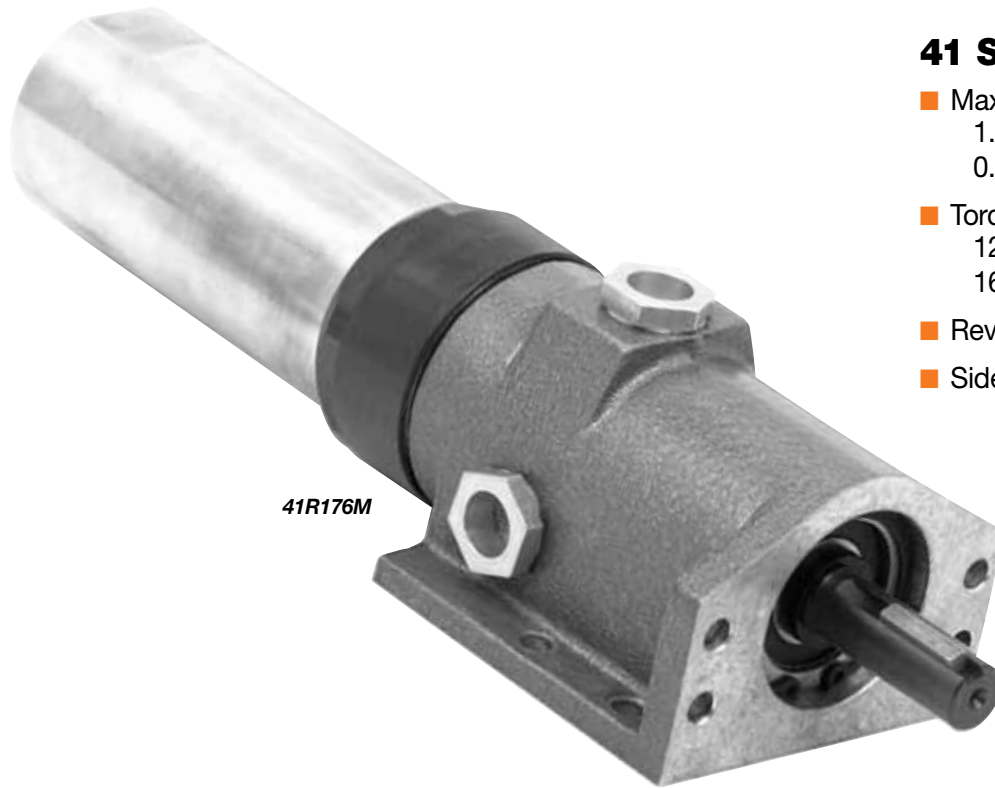

41 Series

- Maximum Power
1.0 hp
0.75 kW
- Torque Range
12 – 63 ft. lbs.
16.3 – 85.4 Nm
- Reversible
- Side Exhaust

41R176M

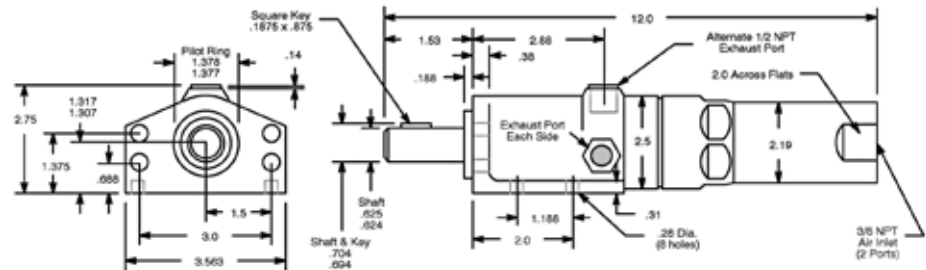
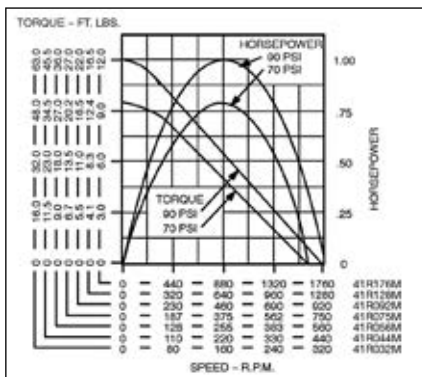

Model Number	RPM		Stall Torque		Weight		Gear Ratio	Max. Overhung Load @ Stall*	
	at Max. hp	Free Speed	ft. lbs.	Nm	lbs.	kg		lbs.	kg

Foot and Flange Mounting – 5/8" Diameter Keyed Spindle

41R176M	880	1760	12.0	16.3	6.25	2.84	7.2:1	600	272
41R128M	640	1280	16.5	22.4	6.25	2.84	9.86:1	600	272
41R092M	460	920	22.0	30.0	6.25	2.84	13.7:1	600	272
41R075M	375	750	27.0	36.6	6.50	2.95	16.8:1	600	272
41R056M	255	560	36.0	48.8	6.50	2.95	22.6:1	600	272
41R044M	220	440	45.5	61.7	6.50	2.95	28.4:1	600	272
41R032M	160	320	63.0	85.4	6.50	2.95	39:1	600	272

*All models assume overhung load located at 1.0" (25.40mm) from face of motor.

General:

Air Inlet: 3/8" NPTF
Air consumption: 33 cfm (.93 m³/min)
All tools performance rated @ 90psi (620 kPa) air pressure.

Standard Equipment:

Air strainer intake fitting. Foot and flange type mount.

Optional Equipment:

Pilot Ring – Part 520886
Lubricating Oil – Part 533485 (1 gallon)

Additional Accessories: Pages 64-65

Cleco®

60 Series

- Maximum Power
2.3 hp
1.72 kW
- Torque Range
50 – 120 ft. lbs.
68 – 163 Nm
- Non-Reversible
- Side Exhaust

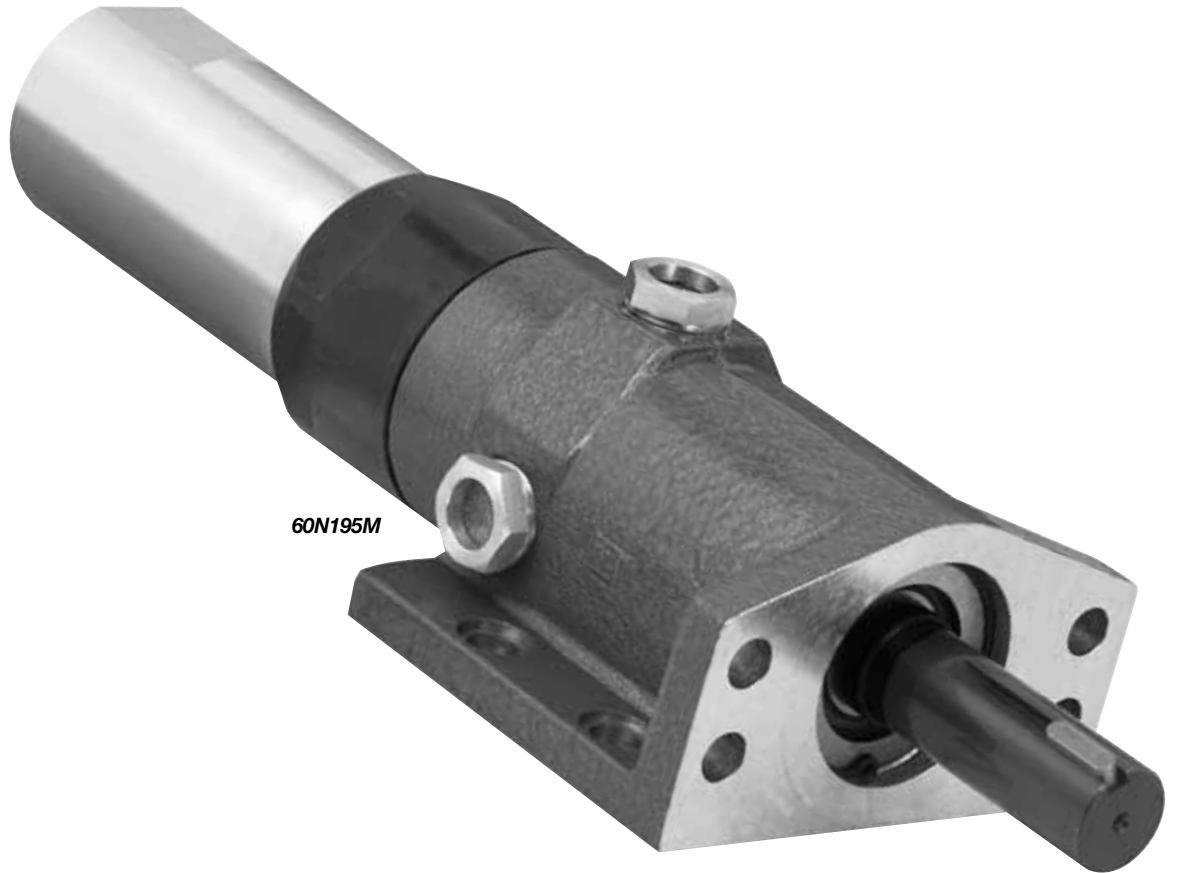

60N195M

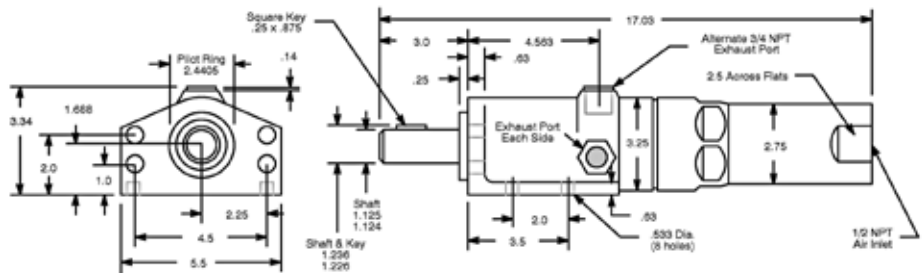
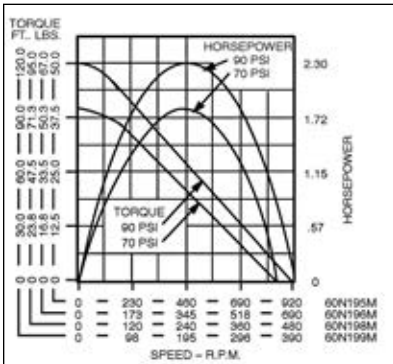

Model Number	RPM		Stall Torque		Weight		Gear Ratio	Max. Overhung Load @ Stall*	
	at Max. hp	Free Speed	ft lbs.	Nm	lbs.	kg		lbs.	kg
60N195M	460	920	50	68	15	6.8	14.2:1	1000	454
60N196M	345	690	67	91	15	6.8	19:1	1000	454
60N198M	240	480	95	129	15	6.8	27:1	1000	454
60N199M	195	390	120	163	15	6.8	33.7:1	1000	454

Foot and Flange Mounting – 1-1/8" Diameter Keyed Spindle

60N195M	460	920	50	68	15	6.8	14.2:1	1000	454
60N196M	345	690	67	91	15	6.8	19:1	1000	454
60N198M	240	480	95	129	15	6.8	27:1	1000	454
60N199M	195	390	120	163	15	6.8	33.7:1	1000	454

*All models assume overhung load located at 2.0" (50.80mm) from face of motor.

General:

Air Inlet: 1/2" NPTF
Air consumption: 70 cfm (1.98 m³/min)
All tools performance rated @ 90psi (620 kPa) air pressure.

Standard Equipment:

Air strainer intake fitting. Foot and flange type mount.

Optional Equipment:

Lubricating Oil – Part 533485 (1 gallon)

Additional Accessories: Pages 64-65

60 Series

- Maximum Power
1.9 hp
1.42 kW
- Torque Range
43 – 101 ft. lbs.
58 – 137 Nm
- Reversible
- Side Exhaust

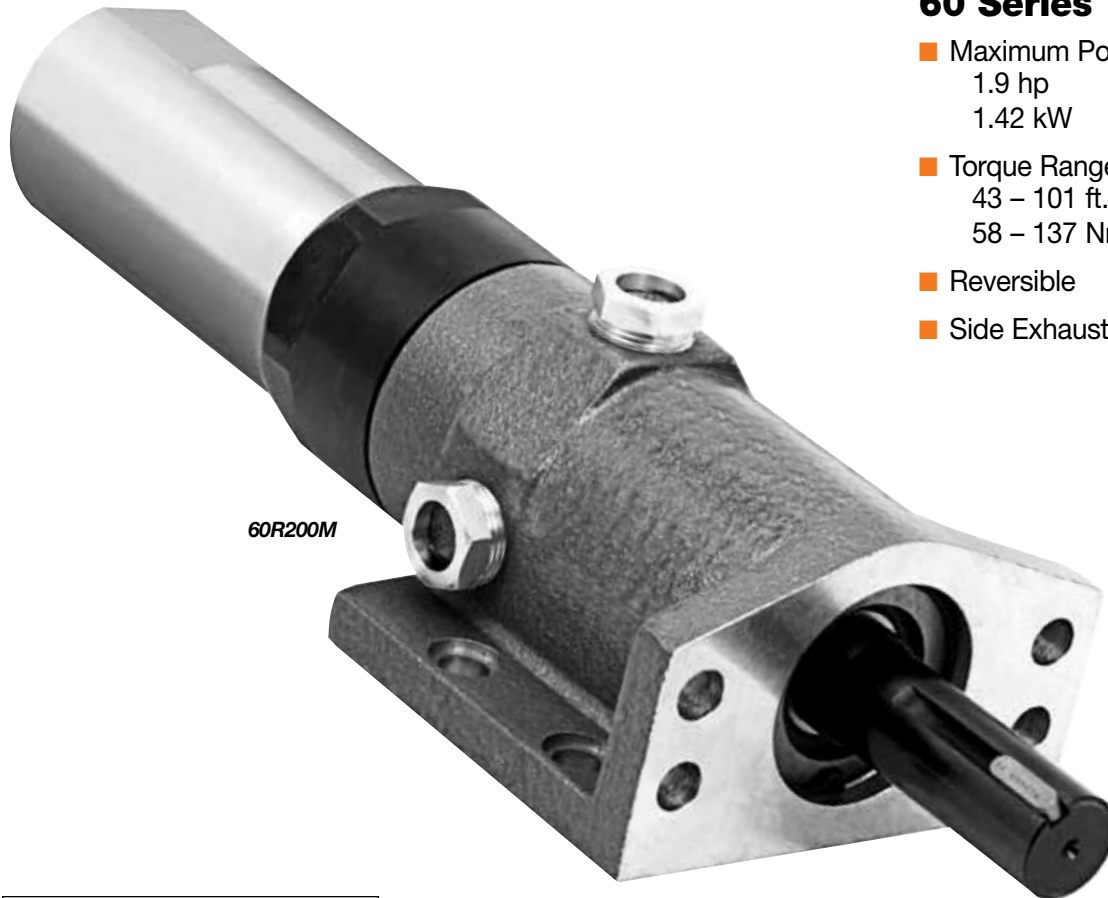

60R200M

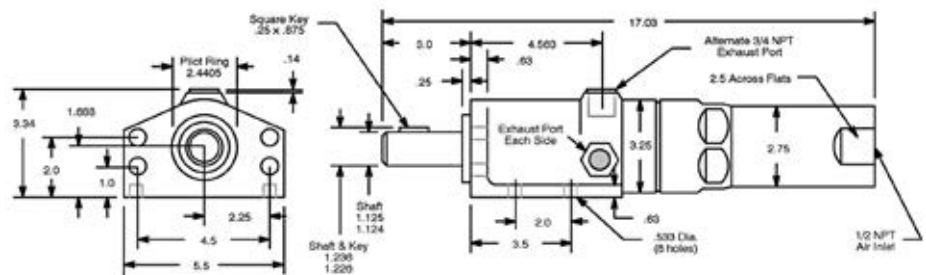
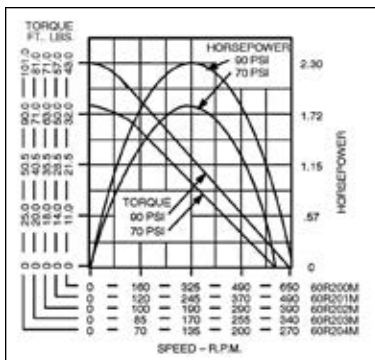

Model Number	RPM		Stall Torque		Weight		Gear Ratio	Max. Overhung Load @ Stall*	
	at Max. hp	Free Speed	ft lbs.	Nm	lbs.	kg		lbs.	kg

Foot and Flange Mounting – 1-1/8" Diameter Keyed Spindle

60R200M	325	650	43	58	15	6.8	14.2:1	1000	454
60R201M	245	490	57	77	15	6.8	19:1	1000	454
60R202M	195	390	71	96	15	6.8	23.7:1	1000	454
60R203M	170	340	81	110	15	6.8	27:1	1000	454
60R204M	135	270	101	137	15	6.8	33.7:1	1000	454

*All models assume overhung load located at 2.0" (50.80mm) from face of motor.

General:

Air Inlet: 1/2" NPTF
Air consumption: 70 cfm (1.98 m3/min)
All tools performance rated @ 90psi (620 kPa) air pressure.

Standard Equipment:

Air strainer intake fitting. Foot and flange type mount.

Optional Equipment:

Lubricating Oil – Part 533485 (1 gallon)

Additional Accessories: Pages 64-65

Cleco®

MR10 Series

- Maximum Power
1.0 hp
0.75 kW
- Torque Range
2.5 – 74 ft. lbs.
3.4 – 100 Nm
- Reversible
- Side Exhaust

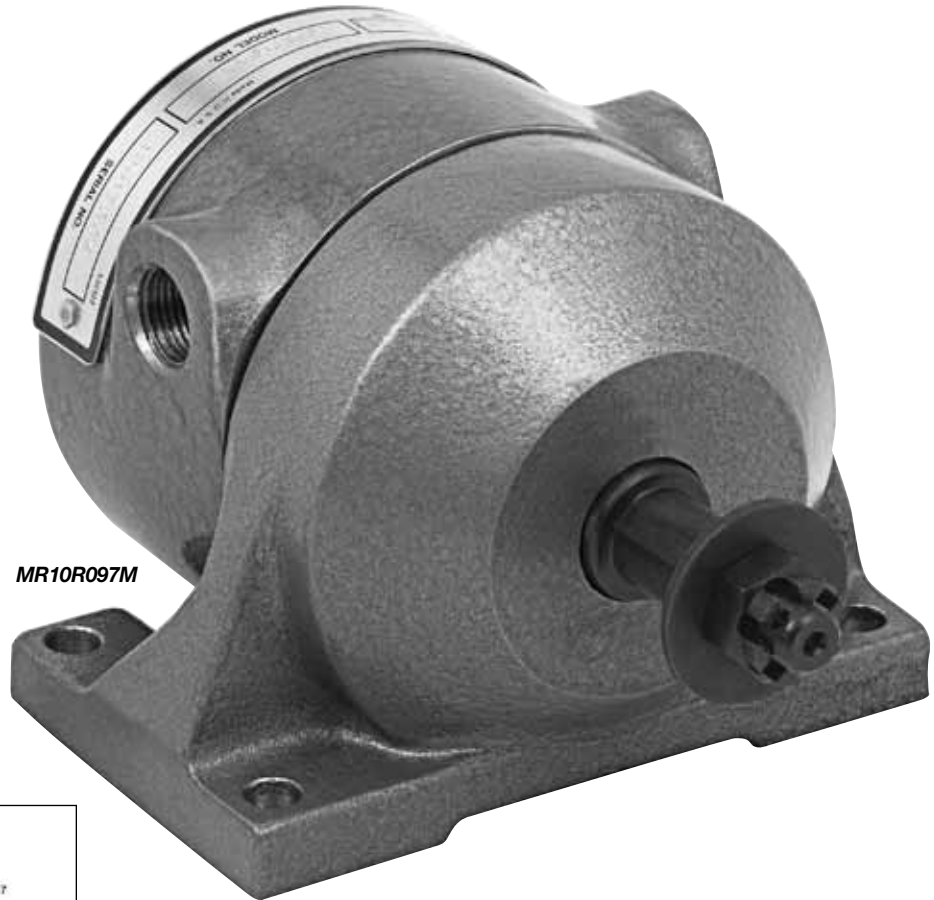

MR10R097M

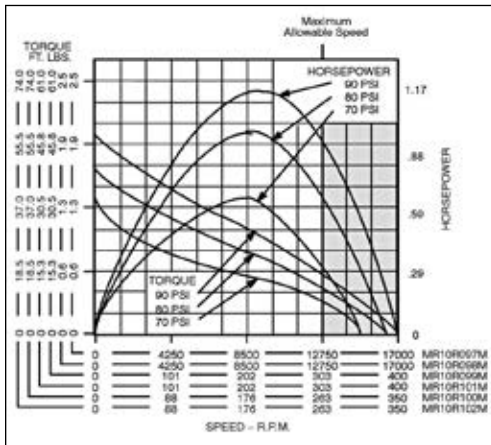

Model Number	RPM		Stall Torque		Starting Torque		Weight		Gear Ratio	Max. Overhung Load @ Stall*	
	at Max. hp	Free Speed	ft lbs.	Nm	ft lbs.	Nm	lbs.	kg		lbs.	kg
Foot Mounting – 5/8" (Non-geared) or 7/8" (Geared) Diameter Keyed Spindle											
MR10R097M	8500	17000	2.5	3.4	1.8	2.4	7	3.2	—	680	308
MR10R099M	210	400	61.0	83.0	35.0	47.0	23	10.4	29.7:1	1055	478
MR10R100M	183	350	74.0	100.0	46.0	62.0	23	10.4	34.2:1	1055	478
Flange Mounting – 5/8" (Non-geared) or 7/8" (Geared) Diameter Keyed Spindle											
MR10R098M	8500	17000	2.5	3.4	1.8	2.4	7	3.2	—	680	308
MR10R101M	210	400	61.0	83.0	35.0	47.0	23	10.4	29.7:1	1055	478
MR10R102M	183	350	74.0	100.0	46.0	62.0	23	10.4	34.2:1	1055	478

*Non-geared models assume overhung load located at 0.5" (12.70mm) from face of motor.
Geared models assume overhung load located at 0.75" (19.05mm) from face of motor.

General:

Air Inlet: 3/8" NPTF
Air consumption: 54 cfm (1.53 m³/min)
All tools performance rated @ 90psi (620 kPa) air pressure.

Standard Equipment:

Air strainer intake fitting. Foot and flange type mount.

Optional Equipment:

Lubricating Oil – Part 533485 (1 gallon)

Additional Accessories: Pages 64-65

MR10 Series Dimensional Data

Non-Geared
MR10R097M
Foot Mounted

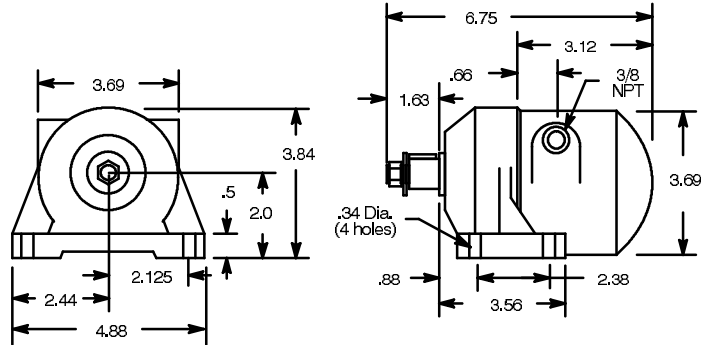
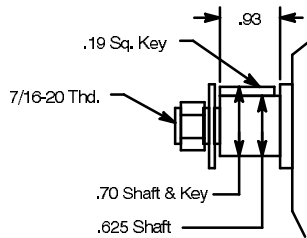

Non-Geared
MR10R098M
Flange Mounted

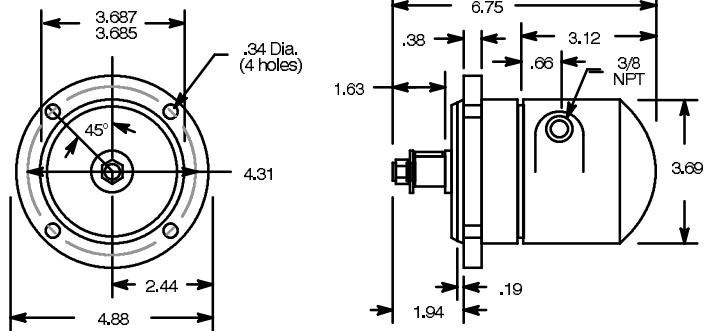

Geared
MR10R099M
MR10R100M
Foot Mounted

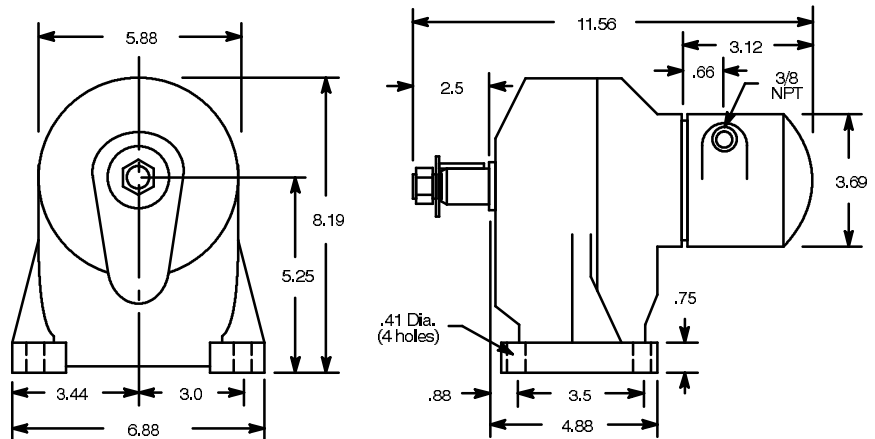
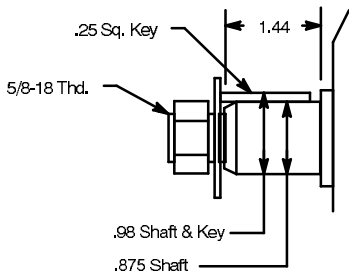

Geared
MR10R101M
MR10R102M
Flange Mounted

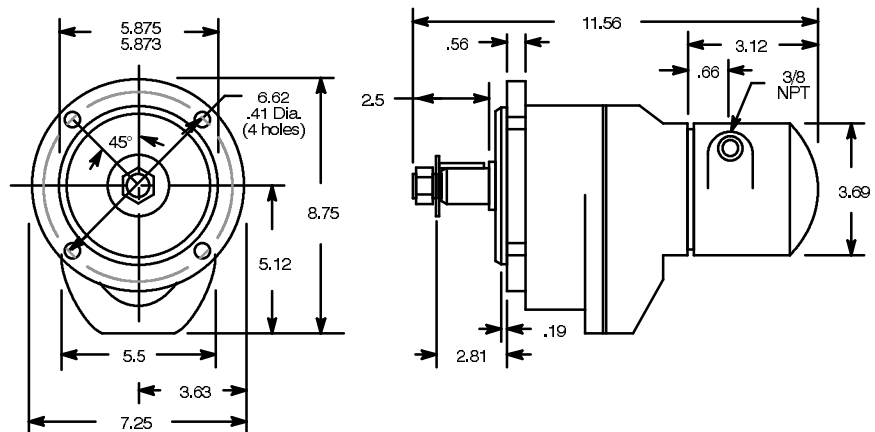

Cleco®

MR30 Series

- Maximum Power
3.0 hp
2.24 kW
- Torque Range
7.2 – 209 ft. lbs.
10 – 283 Nm
- Reversible
- Side Exhaust

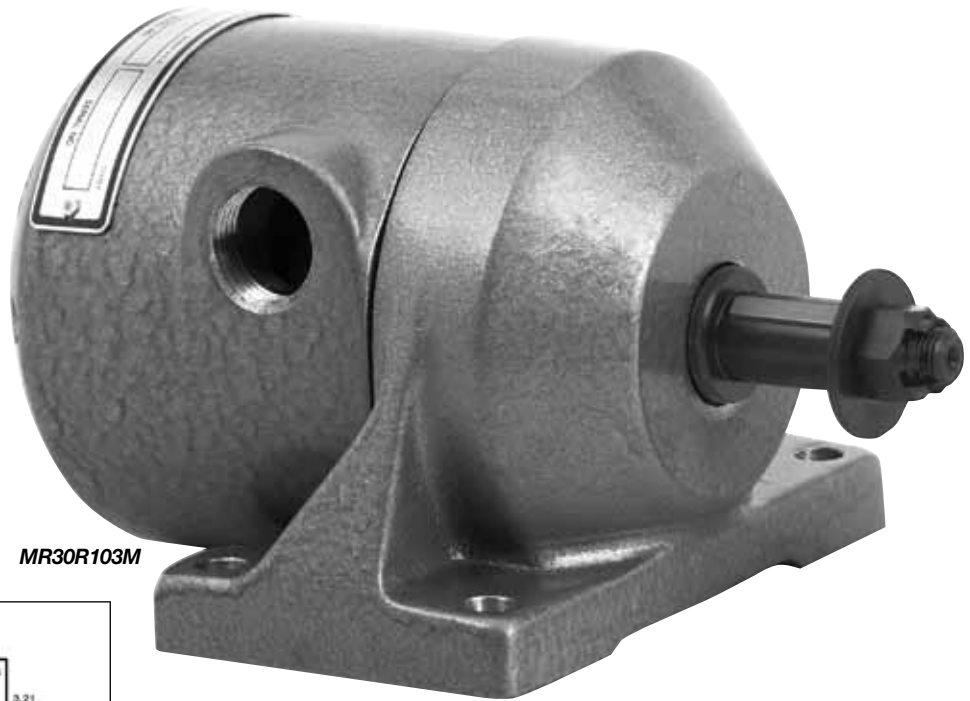

MR30R103M

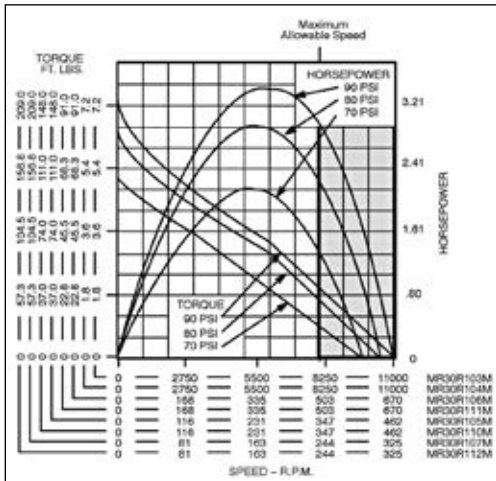

Model Number	RPM		Stall Torque		Starting Torque		Weight		Gear Ratio	Max. Overhung Load @ Stall*	
	at Max. hp	Free Speed	ft lbs.	Nm	ft lbs.	Nm	lbs.	kg		lbs.	kg

Foot Mounting – 3/4" (Non-geared) or 1-1/8" (Geared) Diameter Keyed Spindle

MR30R103M	6000	11000	7.2	10	4.6	6	12.5	5.7	—	1220	553
MR30R106M	366	670	91.0	123	45.0	61	33.0	15.0	16.4:1	1550	703
MR30R105M	252	460	148.0	201	87.0	118	33.0	15.0	23.8:1	1550	703
MR30R107M	177	325	209.0	283	122.0	165	33.0	15.0	23.8:1	1550	703

Flange Mounting – 3/4" (Non-geared) or 1-1/8" (Geared) Diameter Keyed Spindle

MR30R104M	6000	11000	7.2	10	4.6	6	12.5	5.7	—	1220	553
MR30R111M	366	670	91.0	123	45.0	61	33.0	15.0	16.4:1	1550	703
MR30R110M	252	460	148.0	201	87.0	118	33.0	15.0	23.8:1	1550	703
MR30R112M	177	325	209.0	283	122.0	165	33.0	15.0	23.8:1	1550	703

*Non-geared models assume overhung load located at 0.625" (15.88mm) from face of motor.
Geared models assume overhung load located at 0.875" (22.023mm) from face of motor.

General:

Air Inlet: 3/4" NPTF
Air consumption: 124 cfm (3.51 m³/min)
All tools performance rated @ 90psi (620 kPa) air pressure.

Standard Equipment:

Foot and flange type mount.

Optional Equipment:

Exhaust Muffler – Part 524301
Lubricating Oil – Part 533485 (1 gallon)
Gear Oil – Part 535090 (1 gallon)

Additional Accessories: Pages 64-65

MR30 Series Dimensional Data

Non-Geared
MR30R103M
Foot Mounted

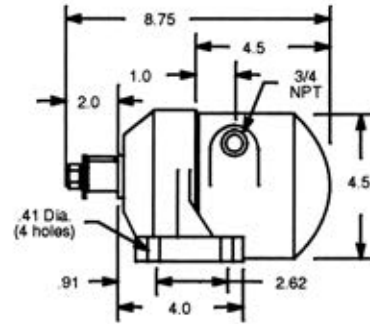
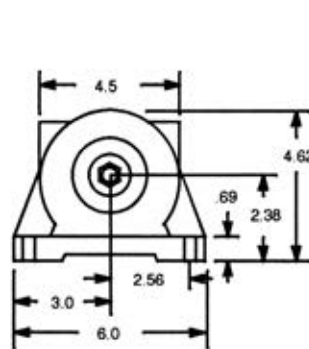
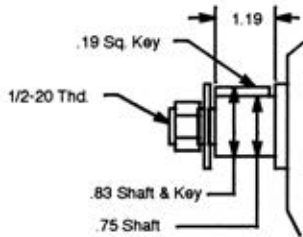

Non-Geared
MR30R104M
Flange Mounted

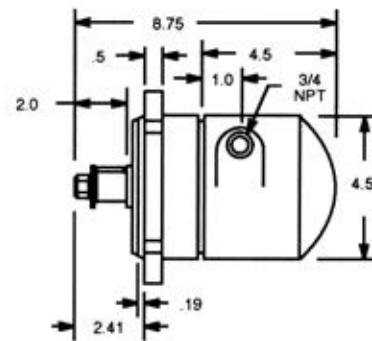
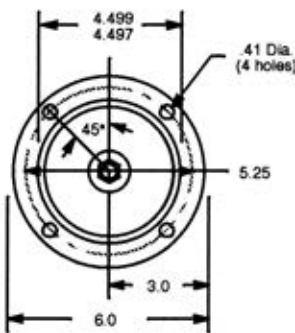

Geared
MR30R106M
MR30R105M
MR30R107M
Foot Mounted

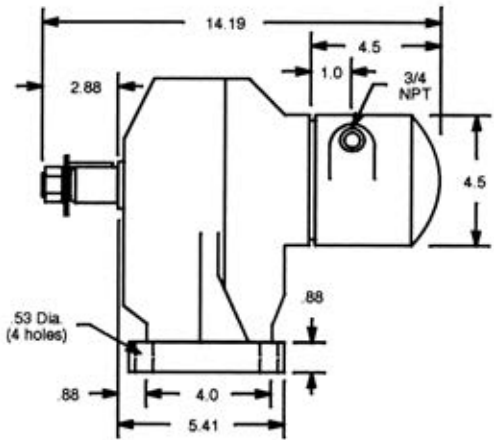
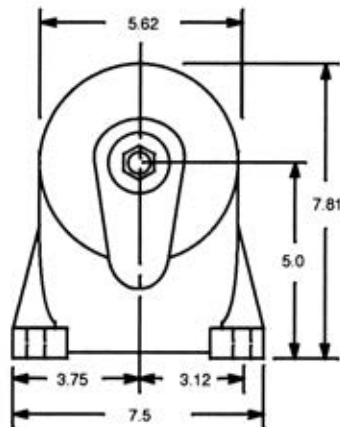
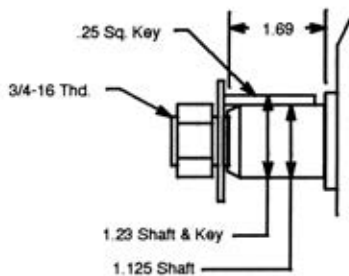

Geared
MR30R111M
MR30R110M
MR30R112M
Flange Mounted

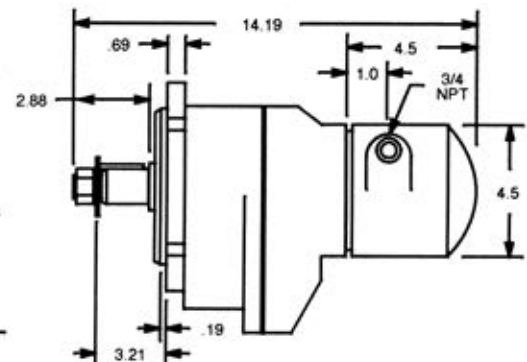
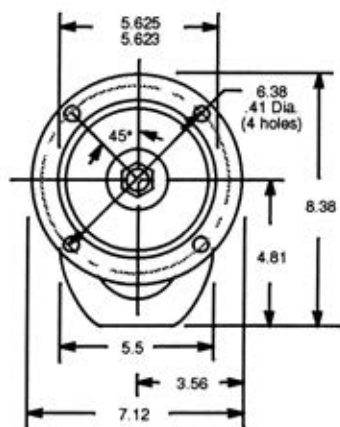

Cleco®

MR50 Series

- Maximum Power
5.5 hp
4.10 kW
- Torque Range
11.9 – 356 ft. lbs.
16 – 483 Nm
- Reversible
- Side Exhaust

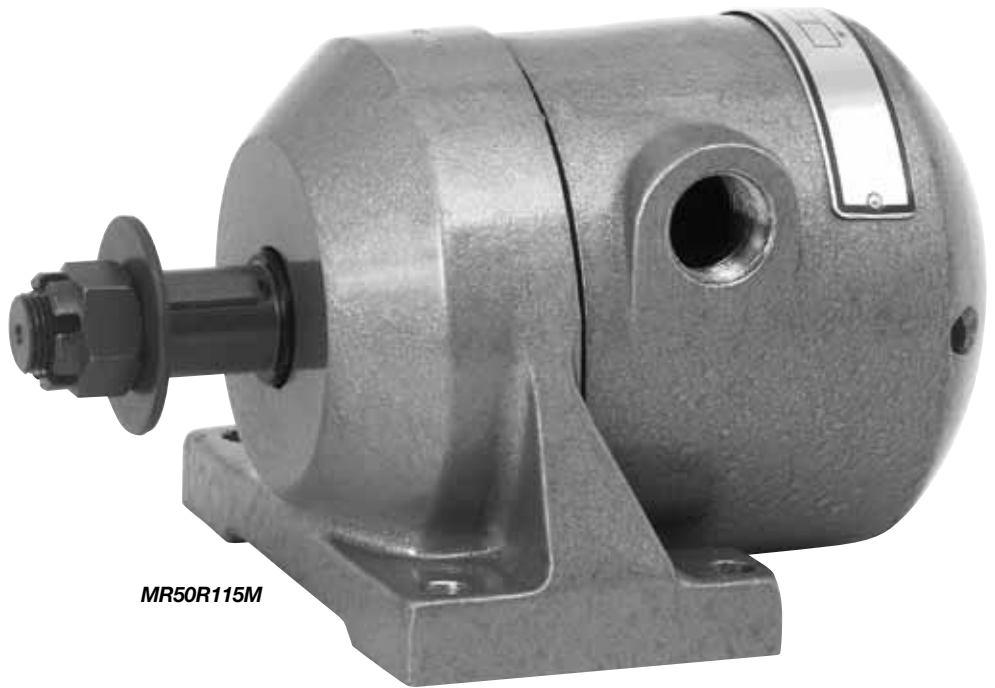

MR50R115M

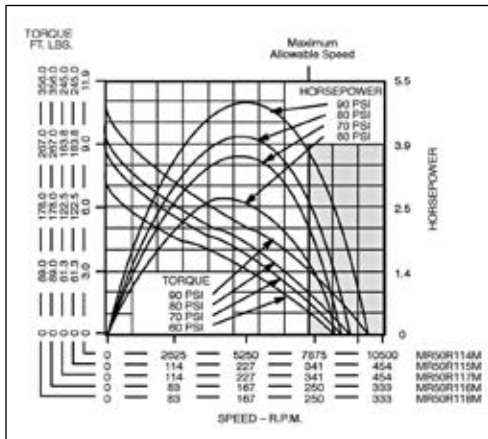

Model Number	RPM		Stall Torque		Starting Torque		Weight		Gear Ratio	Max. Overhung Load @ Stall*	
	at Max. hp	Free Speed	ft lbs.	Nm	ft lbs.	Nm	lbs.	kg		lbs.	kg

Foot Mounting – 1-1/8" (Geared) Diameter Keyed Spindle

MR50R115M	247	450	245.0	332	173.0	235	46.0	21.0	23.1:1	2110	957
MR50R116M	181	330	356.0	483	260.0	353	46.0	21.0	31.58:1	2110	957

Flange Mounting – 1" (Non-geared) or 1-1/8" (Geared) Diameter Keyed Spindle

MR50R114M	5700	10500	11.9	16	8.7	12	18.5	8.4	—	1510	685
MR50R117M	247	450	245.0	332	173.0	235	46.0	21.0	23.1:1	2110	957
MR50R118M	181	330	356.0	483	260.0	353	46.0	21.0	31.58:1	2110	957

*Non-geared models assume overhung load located at 0.625" (15.88mm) from face of motor.
Geared models assume overhung load located at 0.875" (22.023mm) from face of motor.

General:

Air Inlet: 3/4" NPTF
Air consumption: 172 cfm (4.87 m3/min)
All tools performance rated @ 90psi (620 kPa) air pressure.

Standard Equipment:

Foot and flange type mount.

Optional Equipment:

Exhaust Muffler – Part 524301
Lubricating Oil – Part 533485 (1 gallon)
Gear Oil – Part 535090 (1 gallon)

Additional Accessories: Pages 64-65

MR50 Series Dimensional Data

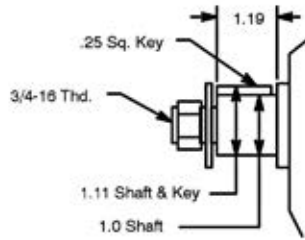

Non-Geared
MR50R114M
Flange Mounted

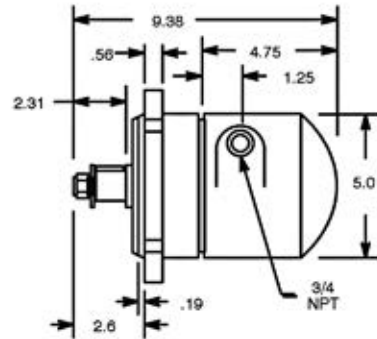
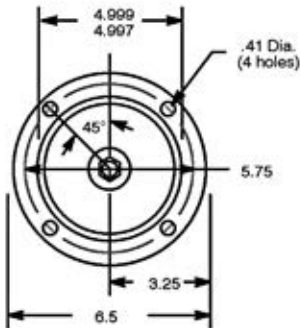

Geared
MR50R115M
MR50R116M
Foot Mounted

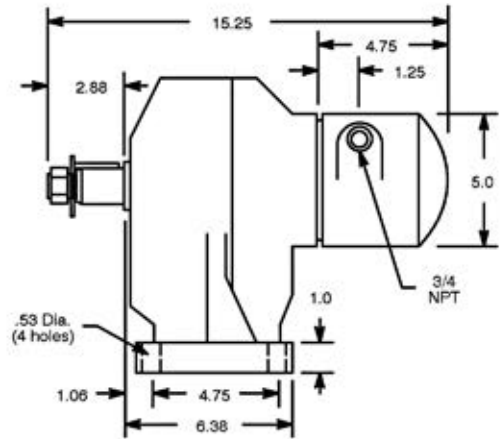
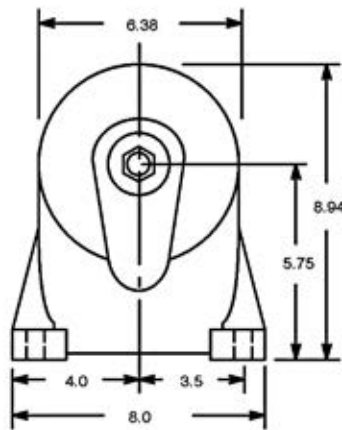
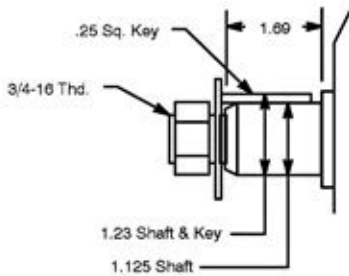

Geared
MR50R117M
MR50R118M
Flange Mounted

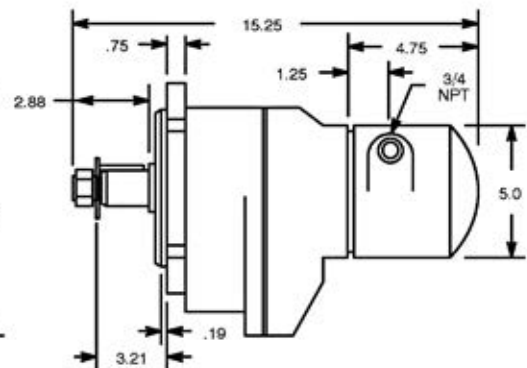
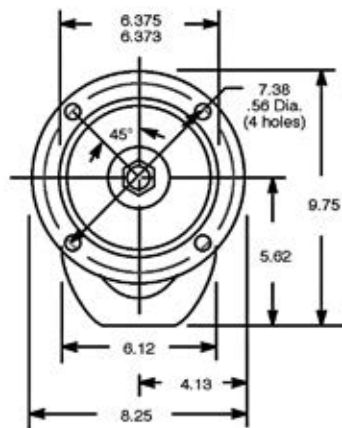

Cleco®

MR70 Series

- Maximum Power
7.5 hp
5.59 kW
- Torque Range
17 – 472 ft. lbs.
23 – 640 Nm
- Reversible
- Side Exhaust

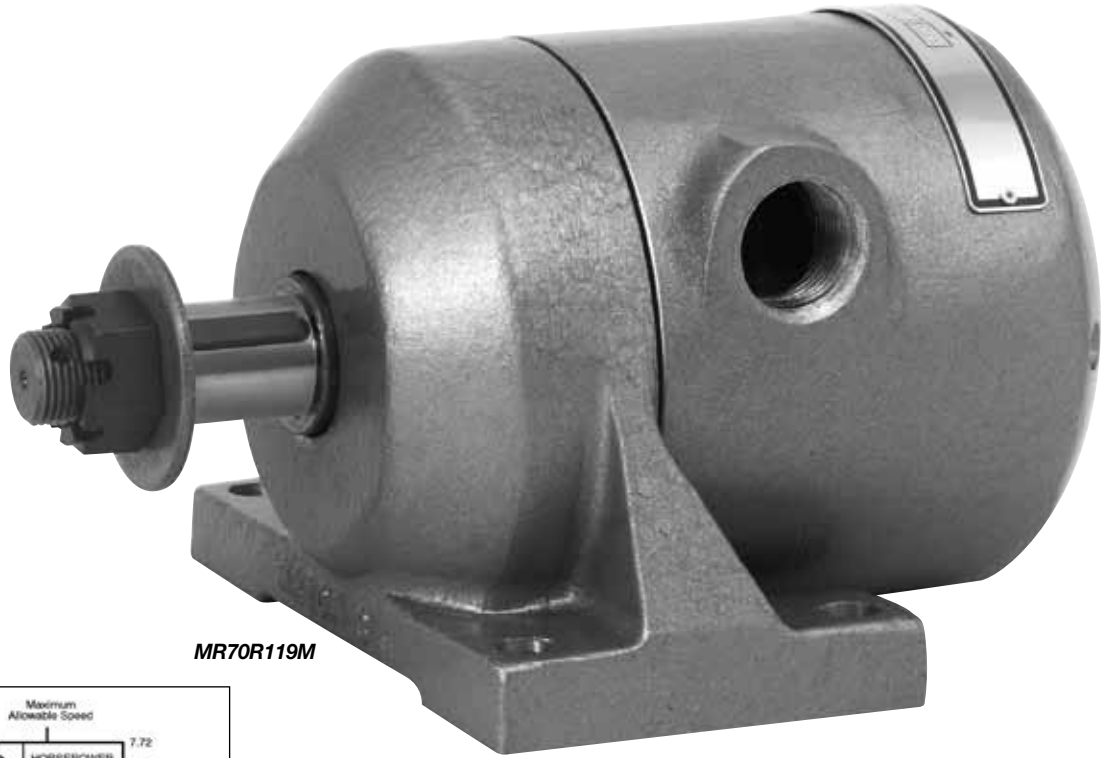

MR70R119M

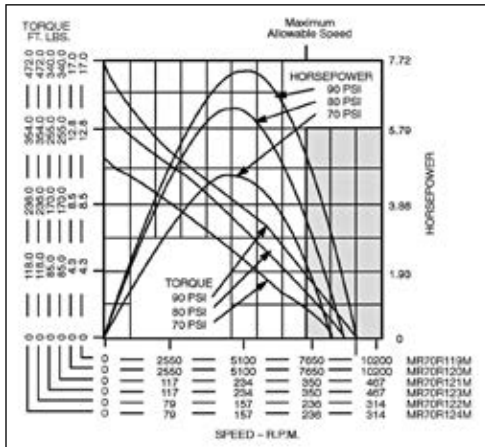

Model Number	RPM		Stall Torque		Starting Torque		Weight		Gear Ratio	Max. Overhung Load @ Stall*	
	at Max. hp	Free Speed	ft lbs.	Nm	ft lbs.	Nm	lbs.	kg		lbs.	kg

Foot Mounting – 1-1/8" (Non-geared) or 1-1/4" (Geared) Diameter Keyed Spindle

MR70R119M	5500	10200	17	23	12	16	27.5	12.5	—	2080	943
MR70R121M	257	465	340	461	227	308	65.0	29.0	21.8:1	2560	1161
MR70R122M	169	310	472	640	336	456	65.0	29.0	32.5:1	2560	1161

Flange Mounting – 1-1/8" (Non-geared) or 1-1/4" (Geared) Diameter Keyed Spindle

MR70R120M	5500	10200	17	23	12	16	27.5	12.5	—	2080	943
MR70R123M	257	465	340	461	227	308	65.0	29.0	21.8:1	2560	1161
MR70R124M	169	310	472	640	336	456	65.0	29.0	32.5:1	2560	1161

*Non-geared models assume overhung load located at 0.75" (19.05mm) from face of motor.
Geared models assume overhung load located at 1" (25.40mm) from face of motor.

General:

Air Inlet: 1" NPTF
Air consumption: 212 cfm (6.00 m3/min)
All tools performance rated @ 90psi (620 kPa) air pressure.

Standard Equipment:

Foot and flange type mount.

Optional Equipment:

Exhaust Muffler – Part 524302
Lubricating Oil – Part 533485 (1 gallon)
Gear Oil – Part 535090 (1 gallon)

Additional Accessories: Pages 64-65

MR70 Series Dimensional Data

**Non-Geared
MR70R119M
Foot Mounted**

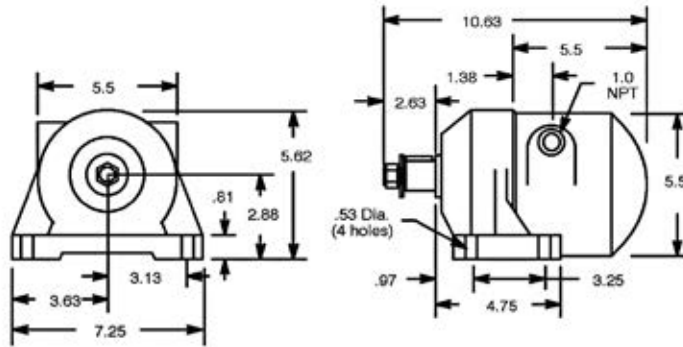
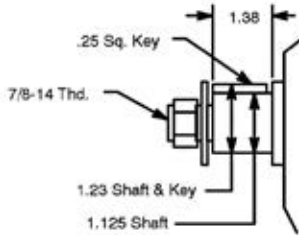

**Non-Geared
MR70R120M
Flange Mounted**

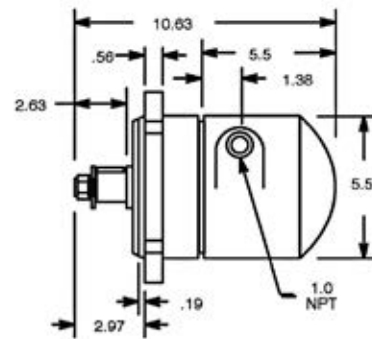
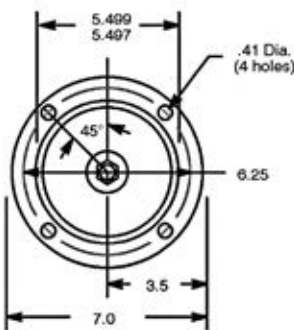

**Geared
MR70R121M
Foot Mounted**

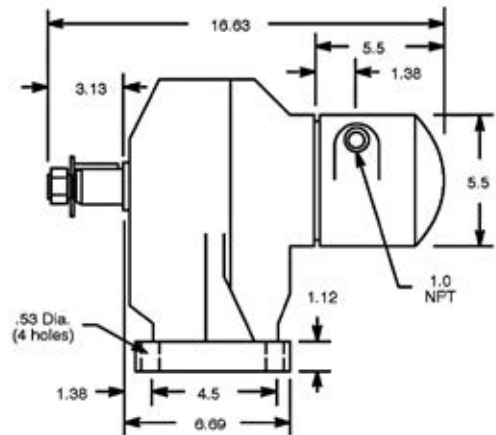
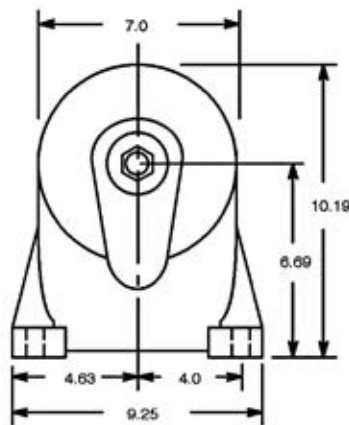
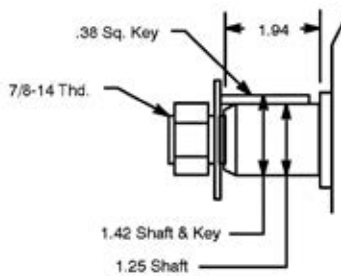

**Geared
MR70R123M
MR70R124M
Flange Mounted**

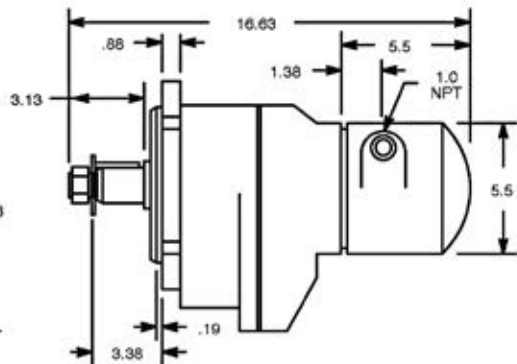
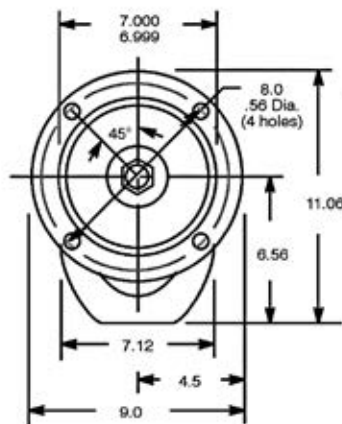

Cleco®

A2 Series

- Maximum Power
0.6 hp
0.45 kW
- Torque Range
2 – 107 ft. lbs.
2.7 – 145 Nm
- Reversible
- Rear Exhaust



A2R300M

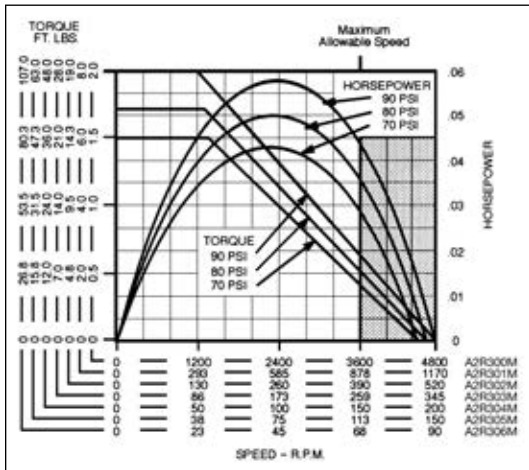

Model Number	RPM**		Stall Torque		Starting Torque		Weight		Gear Ratio	Max. Overhung Load @ Stall*	
	at Max. hp	Free Speed	ft lbs.	Nm	ft lbs.	Nm	lbs.	kg		lbs.	kg

Face Mounting – 7/8" Diameter Keyed Spindle

A2R300M	2360	4800	2	2.7	1.5	2	14	6.35	—	800	363
A2R301M	575	1170	8	11.0	6.0	8	14	6.35	4.1:1	800	363
A2R302M	255	520	19	26.0	13.0	18	14	6.35	9.25:1	800	363
A2R303M	169	345	28	38.0	21.0	28	22	9.98	13.9:1	800	363
A2R304M	99	200	48	65.0	36.0	49	22	9.98	23.8:1	800	363
A2R305M	75	150	63	85.0	47.0	64	22	9.98	31.4:1	800	363
A2R306M	44	90	107	145.0	80.0	108	22	9.98	53.6:1	800	363

* All models assume overhung load located at 1.75" (44.45mm) from face of motor.

** These motors must be operated with sufficient load to prevent speed from exceeding maximum allowable speed shown on performance curve.

General:

Air Inlet: 1" NPTF

Air consumption: 212 cfm (6.00 m3/min)

All tools performance rated @ 90psi (620 kPa) air pressure.

Standard Equipment:

Foot and flange type mount.

Optional Equipment:

Exhaust Muffler – Part 524302

Lubricating Oil – Part 533485 (1 gallon)

Gear Oil – Part 535090 (1 gallon)

Additional Accessories: Pages 64-65

A2 Series Dimensional Data

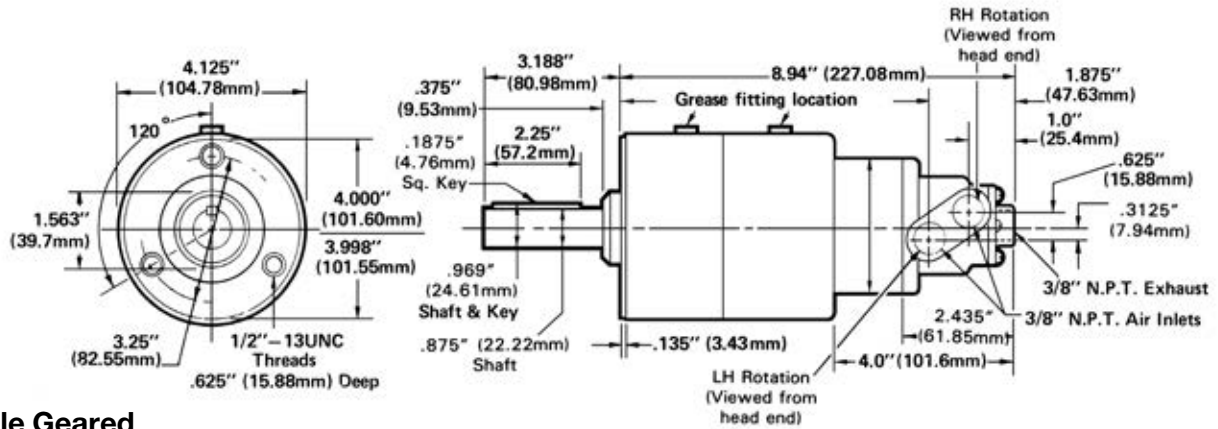

Single Geared

- A2R300M
- A2R301M
- A2R302M

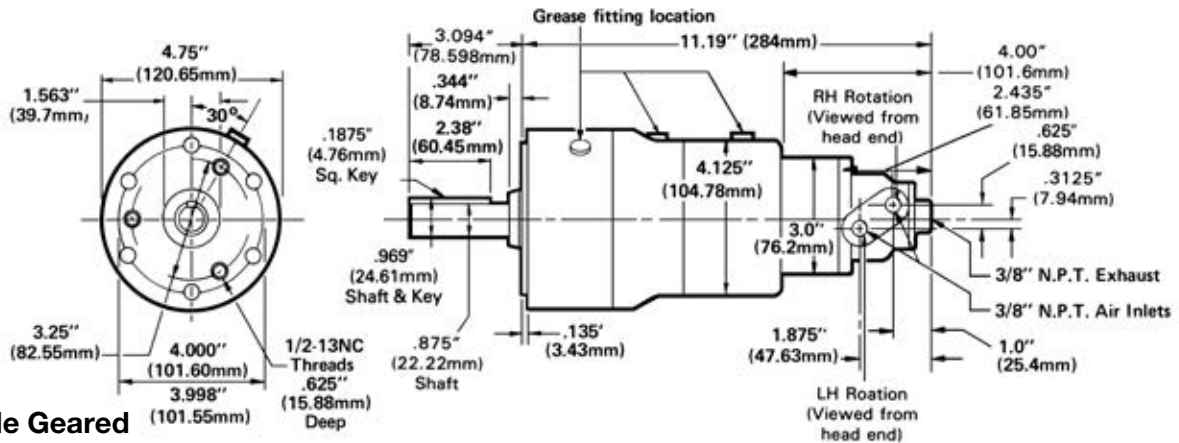

Double Geared

- A2R303M
- A2R304M
- A2R305M
- A2R306M



B4 Series

- Maximum Power
0.9 hp
0.67 kW
- Torque Range
4 – 232 ft. lbs.
6.8 – 315 Nm
- Reversible
- Rear Exhaust

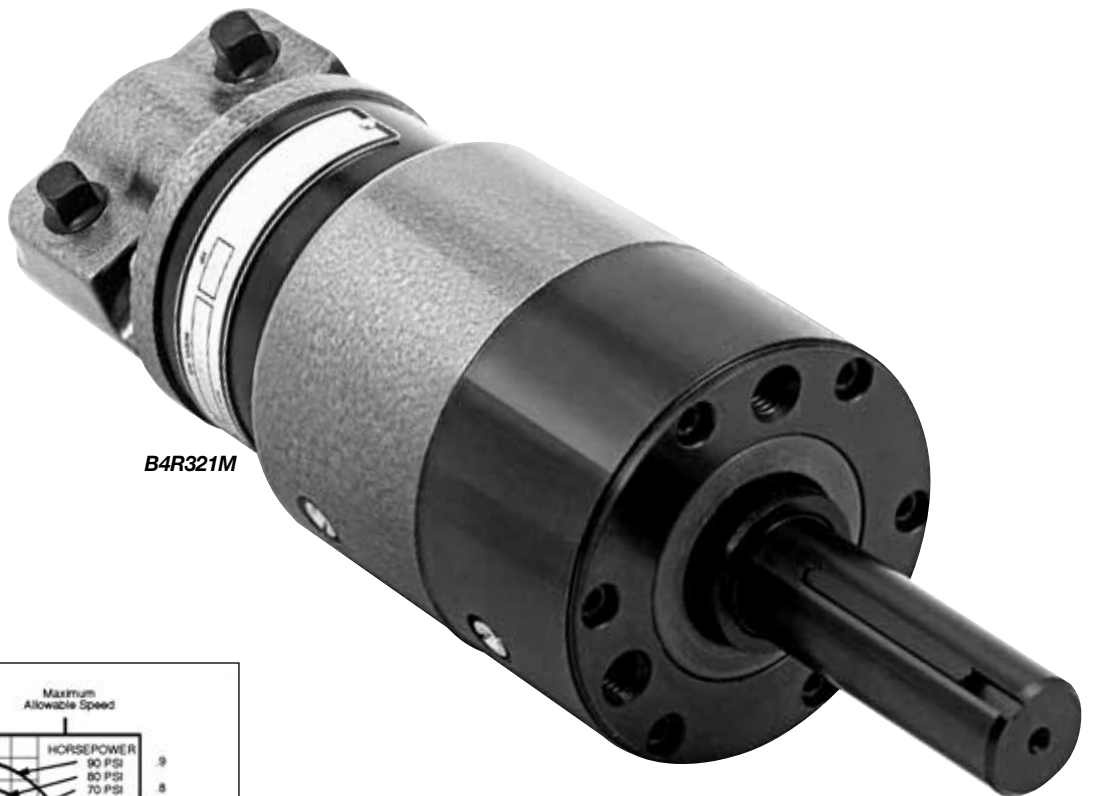

B4R321M

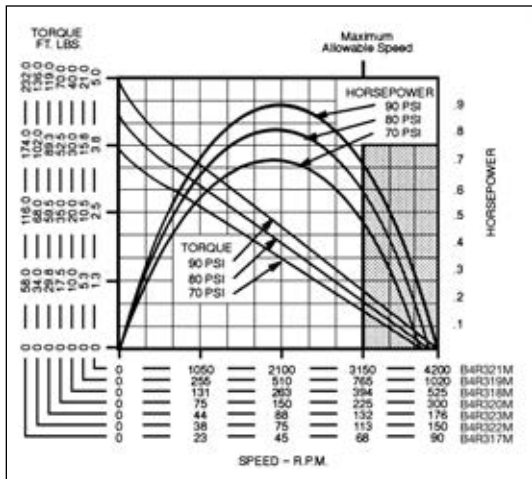

Model Number	RPM**		Stall Torque		Starting Torque		Weight		Gear Ratio	Max. Overhung Load @ Stall*	
	at Max. hp	Free Speed	ft lbs.	Nm	ft lbs.	Nm	lbs.	kg		lbs.	kg

Face Mounting – 7/8" Diameter Keyed Spindle

B4R321M	2150	4200	5	6.8	3.7	5	14.5	6.57	—	800	363
B4R319M	525	1020	21	28.0	15.0	20	14.5	6.57	4.1:1	800	363
B4R318M	270	525	40	54.0	30.0	41	14.5	6.57	8:1	800	363
B4R320M	154	300	70	95.0	52.0	71	22.5	10.21	13.9:1	800	363
B4R323M	90	175	119	161.0	88.0	119	22.5	10.21	23.8:1	800	363
B4R322M	79	150	136	184.0	101.0	137	22.5	10.21	27.2:1	800	363
B4R317M	46	90	232	315.0	172.0	233	22.5	10.21	46.4:1	800	363

* All models assume overhung load located at 1.75" (44.45mm) from face of motor.

** These motors must be operated with sufficient load to prevent speed from exceeding maximum allowable speed shown on performance curve.

General:

Air Inlet: 3/8" NPTF

Air consumption: 40 cfm (1.13 m³/min)

All tools performance rated @ 90psi (620 kPa) air pressure.

Optional Equipment:

Exhaust Muffler – Part 813485

Pendent Control Kits – See page 51

Lubricating Oil – Part 533485 (1 gallon)

Motor and Gear Lube – Part A123771 (1 pound)

Additional Accessories: Pages 64-65

B4 Series Dimensional Data

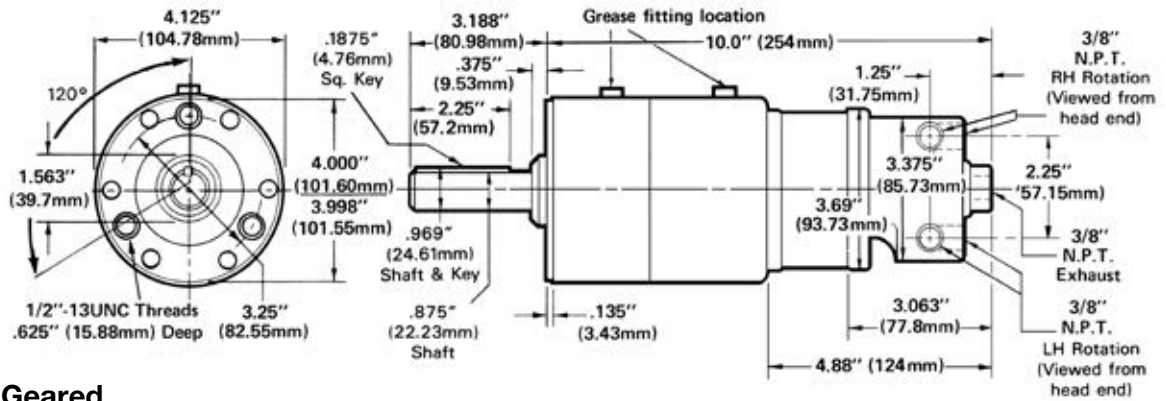

Single Geared

- B4R321M
- B4R319M
- B4R318M

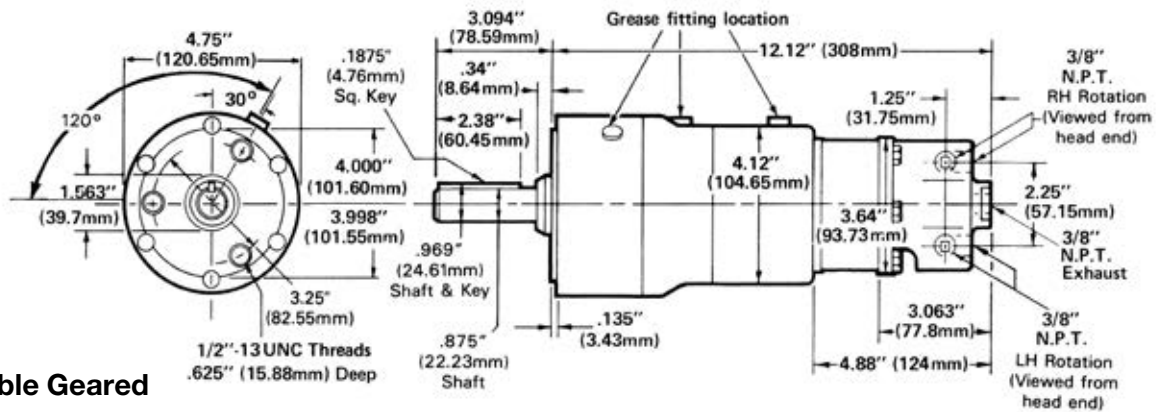

Double Geared

- B4R317M
- B4R320M
- B4R322M
- B4R323M

Cleco®

A6 Series

- Maximum Power
1.9 hp
1.42 kW
- Torque Range
11 – 370 ft. lbs.
15 – 502 Nm
- Reversible
- Rear Exhaust



A6R308M

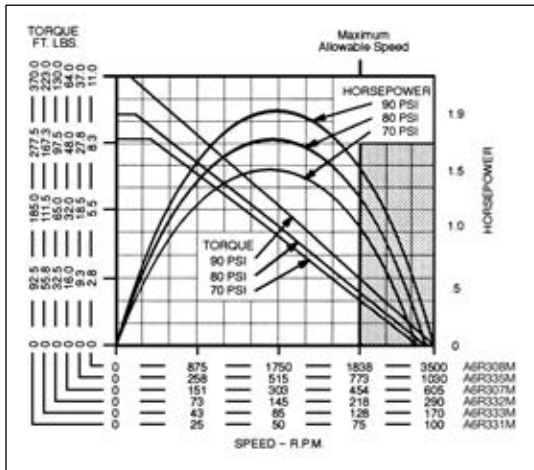

Model Number	RPM**		Stall Torque		Starting Torque		Weight		Gear Ratio	Max. Overhung Load @ Stall*	
	at Max. hp	Free Speed	ft lbs.	Nm	ft lbs.	Nm	lbs.	kg		lbs.	kg
A6R308M	1820	3500	1	15	8	11	27	12.2	—	1000	454
A6R335M	535	1030	37	50	27	37	27	12.2	3.4:1	1000	454
A6R307M	315	605	64	87	48	65	27	12.2	5.8:1	1000	454
A6R332M	152	290	130	176	96	130	43	19.5	11.9:1	1000	454
A6R333M	89	170	223	302	163	221	43	19.5	20.3:1	1000	454
A6R331M	54	100	370	502	269	365	43	19.5	33.6:1	1000	454

* All models assume overhung load located at 2.25" (57.15mm) from face of motor.

** These motors must be operated with sufficient load to prevent speed from exceeding maximum allowable speed shown on performance curve.

General:

Air Inlet: 3/8" NPTF
Air consumption: 62 cfm (1.76 m3/min)
All tools performance rated @ 90psi (620 kPa) air pressure.

Optional Equipment:

- Exhaust Muffler – Part 813485
- Pendent Control Kits – See page 51
- Lubricating Oil – Part 533485 (1 gallon)
- Motor and Gear Lube – Part A123771 (1 pound)
- Additional Accessories:** Pages 64-65

A6 Series Dimensional Data

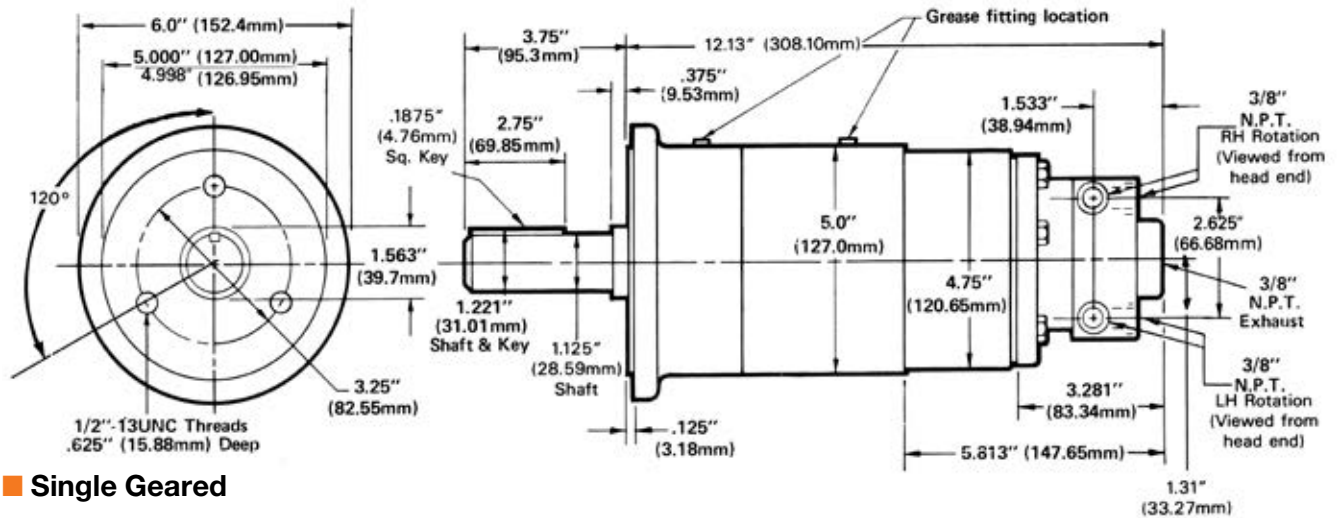

Single Geared

A6R307M
A6R308M
A6R335M

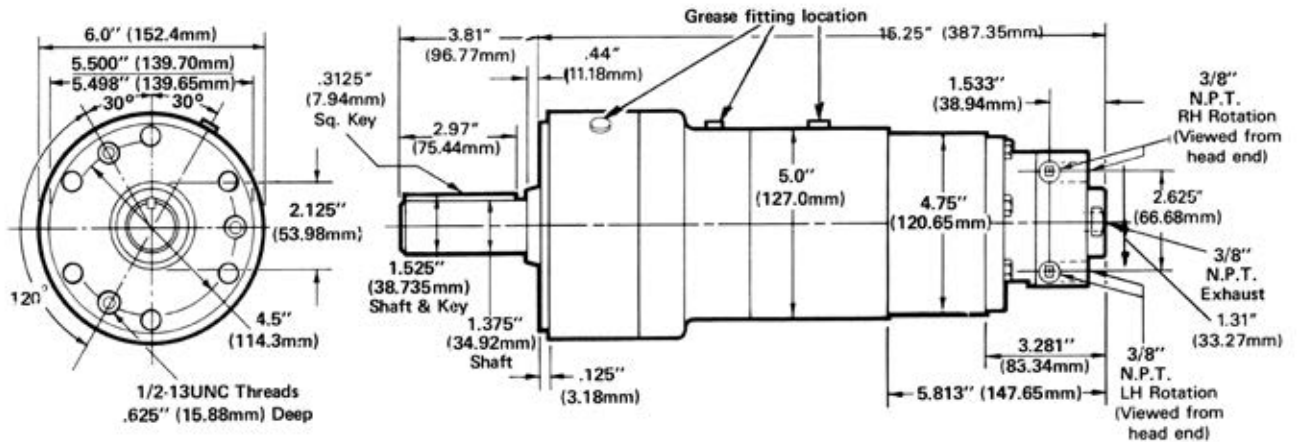

Double Geared

A6R331M
A6R332M

Cleco®

A8 Series

- Maximum Power
2.7 hp
2.01 kW
- Torque Range
19 – 638 ft. lbs.
26 – 865 Nm
- Reversible
- Rear Exhaust

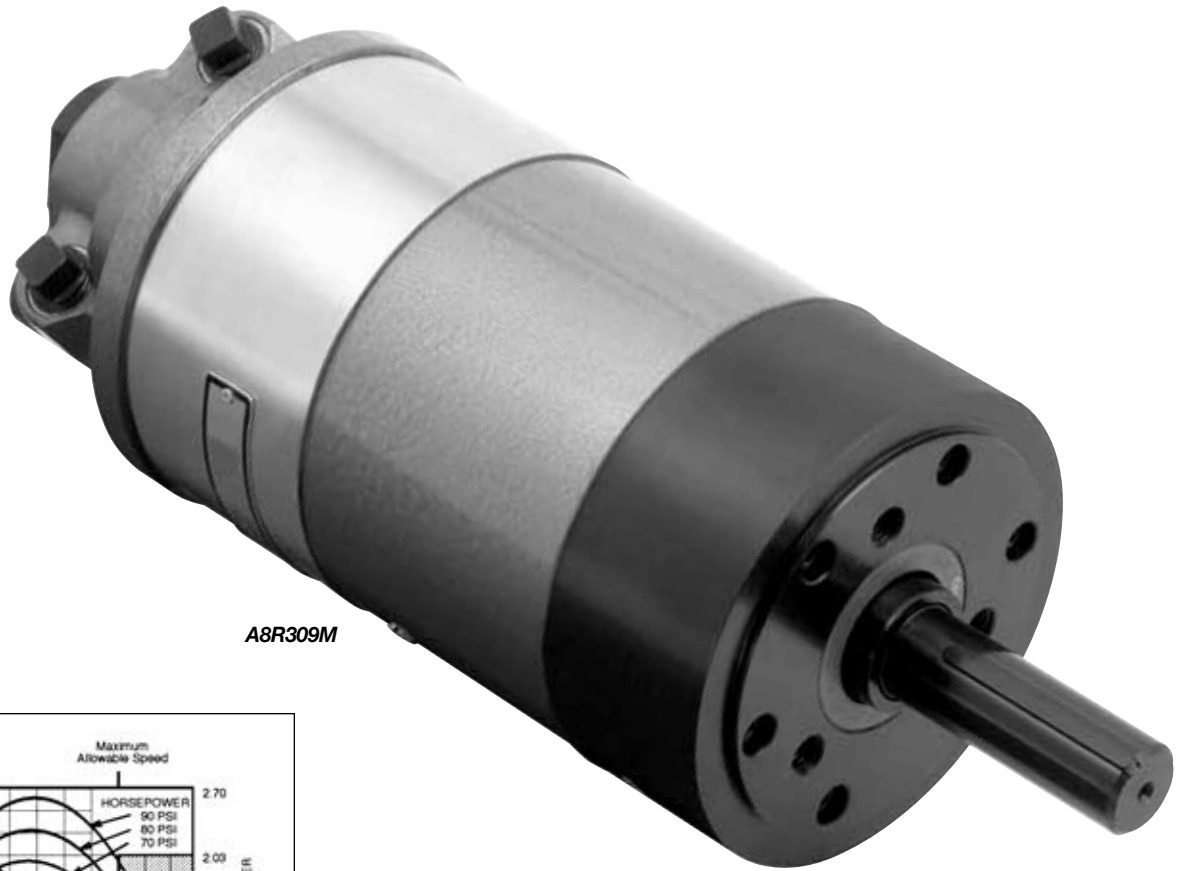

A8R309M

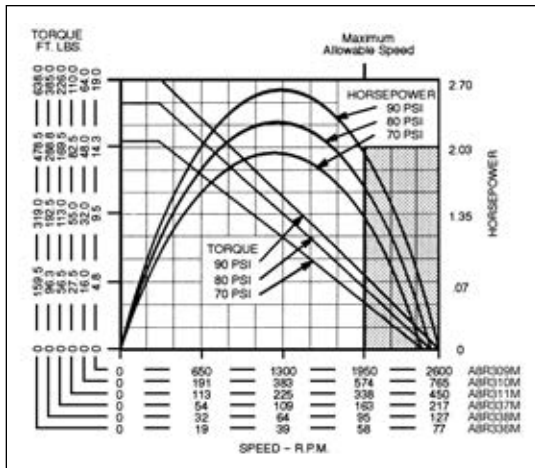

Model Number	RPM**		Stall Torque		Starting Torque		Weight		Gear Ratio	Max. Overhung Load @ Stall*	
	at Max. hp	Free Speed	ft lbs.	Nm	ft lbs.	Nm	lbs.	kg		lbs.	kg

Face Mounting – 1 1/8" Diameter Keyed Spindle

A8R309M	1300	2600	19	26	14	19	38	17.2	—	1000	454
A8R310M	375	765	64	87	48	65	38	17.2	3.4:1	1000	454
A8R311M	225	450	110	149	82	111	38	17.2	5.8:1	1000	454
A8R337M	109	215	226	306	167	226	51	23.1	11.9:1	1000	454
A8R338M	64	125	385	522	285	386	51	23.1	20.3:1	1000	454
A8R336M	38	75	638	865	471	639	51	23.1	33.6:1	1000	454

* All models assume overhung load located at 2.25" (57.15mm) from face of motor.

** These motors must be operated with sufficient load to prevent speed from exceeding maximum allowable speed shown on performance curve.

General:

Air Inlet: 1/2" NPTF

Air consumption: 83 cfm (3.18 m³/min)

All tools performance rated @ 90psi (620 kPa) air pressure.

Optional Equipment:

Exhaust Muffler – Part A19509

Pendent Control Kits – See page 51

Lubricating Oil – Part 533485 (1 gallon)

Motor and Gear Lube – Part A123771 (1 pound)

Additional Accessories: Pages 64-65

A8 Series Dimensional Data

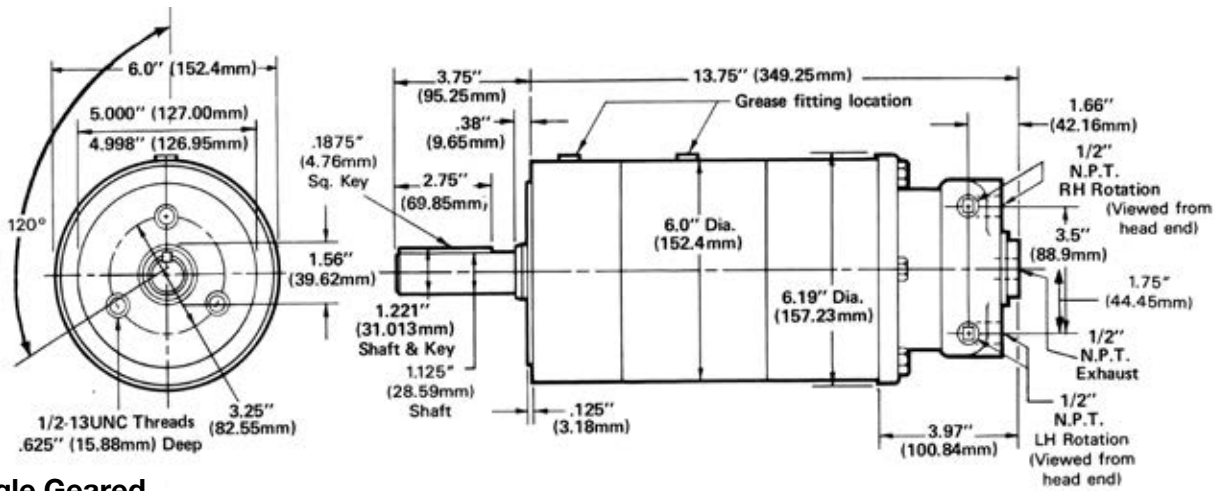

Single Geared

- A8R309M
- A8R310M
- A8R311M

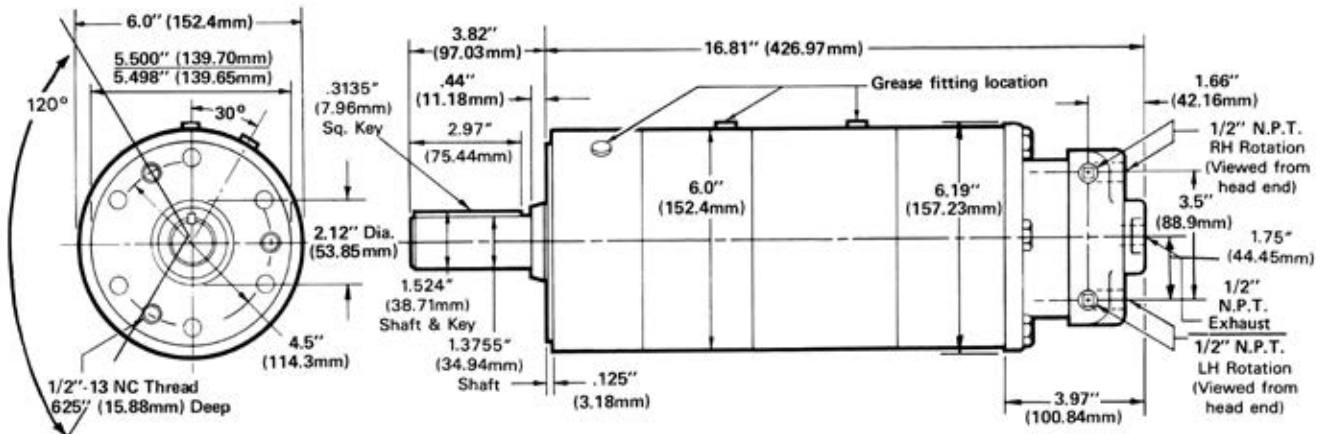

Double Geared

- A8R336M
- A8R337M
- A8R338M

Spindle Information for Axial Piston Motors

The axial piston air motors are equipped with standard spindles, *unless otherwise specified*. If a special spindle is required, the motor is shipped without a spindle; using the dimensions of the shank end of the spindle shown in the dimensional drawing, the customer can make a spindle to fit the requirements of the job.

If other than a standard spindle is required, specify shipment of motor *without spindle* – or provide detailed dimensional information of the spindle required.

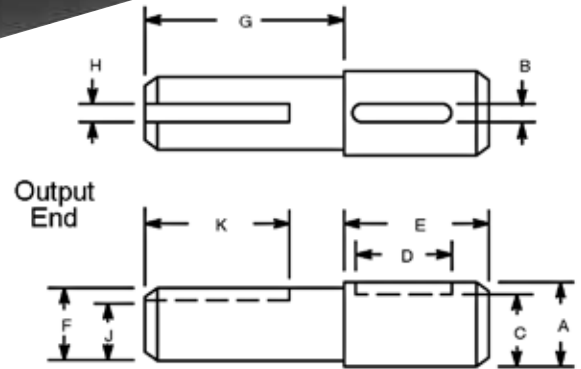
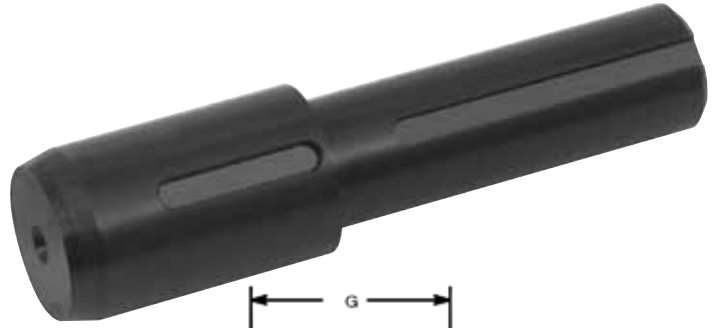

Model Number	Std. Spindle	Dia. "A"	Key Width "B"	Key Depth "C"	Key Slot "D"	"E"	Dia. "F"	"G"	Key Width "H"	Key Depth "J"	Key Slot "K"
Single Geared											
A2R300M	18299				1.125" or 28.57mm	1.875" or 47.62mm	.8750"	2.75 or 69.88mm		.7715"	2.25 or 57.15mm
A2R301M							.8744"			.7665"	
A2R302M							or			or	
B4R321M							22.22mm			19.60mm	
B4R319M							22.21mm			19.47mm	
B4R318M	18319	29.43mm or 29.39mm	4.75mm or 4.80mm	26.83mm or 26.71mm	1.500" or 38.10mm	47.62mm	1.1255"	3.375" or 85.73mm	4.76mm	1.0188"	2.75" or 69.85mm
A6R308M							1.1245"		4.71mm	1.0238"	
A6R335M							or		Sq. Key	or	
A6R307M							28.59mm		25.88mm	26.00mm	
A8R309M							28.56mm				
A8R310M	29717	1.0008" 1.0002" or 25.42mm 25.41mm	.249" .251" or 6.32mm 6.38mm	.859" .849" or 21.82mm 21.56mm	1.125" or 28.57mm	1.875" or 47.62"	.8750"	2.75" or 69.85mm	.1875" or .1855"	.771" or .761"	2.375" or 60.32mm
A2R304M							.8744"		.7665"		
A2R305M							or		or		
A2R306M							22.22mm		19.58mm		
B4R320M							22.21mm		19.33mm		
B4R323M	30053	36.57mm or 36.56mm	9.50mm or 9.55mm	31.12mm or 30.86mm	38.10mm or 38.10mm	50.80mm	1.3755"	3.375" or 85.73mm	.3125" or .3135"	1.201" or 1.191"	3.125" or 79.38mm
B4R322M							or		Sq. Key	or	
B4R317M							34.94mm		30.50mm	30.25mm	
A6R332M							34.91mm				
A6R333M											
A6R331M	30053	36.57mm or 36.56mm	9.50mm or 9.55mm	31.12mm or 30.86mm	38.10mm or 38.10mm	50.80mm	1.3745"	3.375" or 85.73mm	.3135" or Sq. Key	1.191" or 30.25mm	3.125" or 79.38mm
A8R337M							34.94mm		30.50mm	30.25mm	
A8R338M											
A8R337M											



MA2 Series

- Maximum Power
1.5 hp
1.12 kW
- Torque Range
8.6 – 262 ft. lbs.
12 – 355 Nm

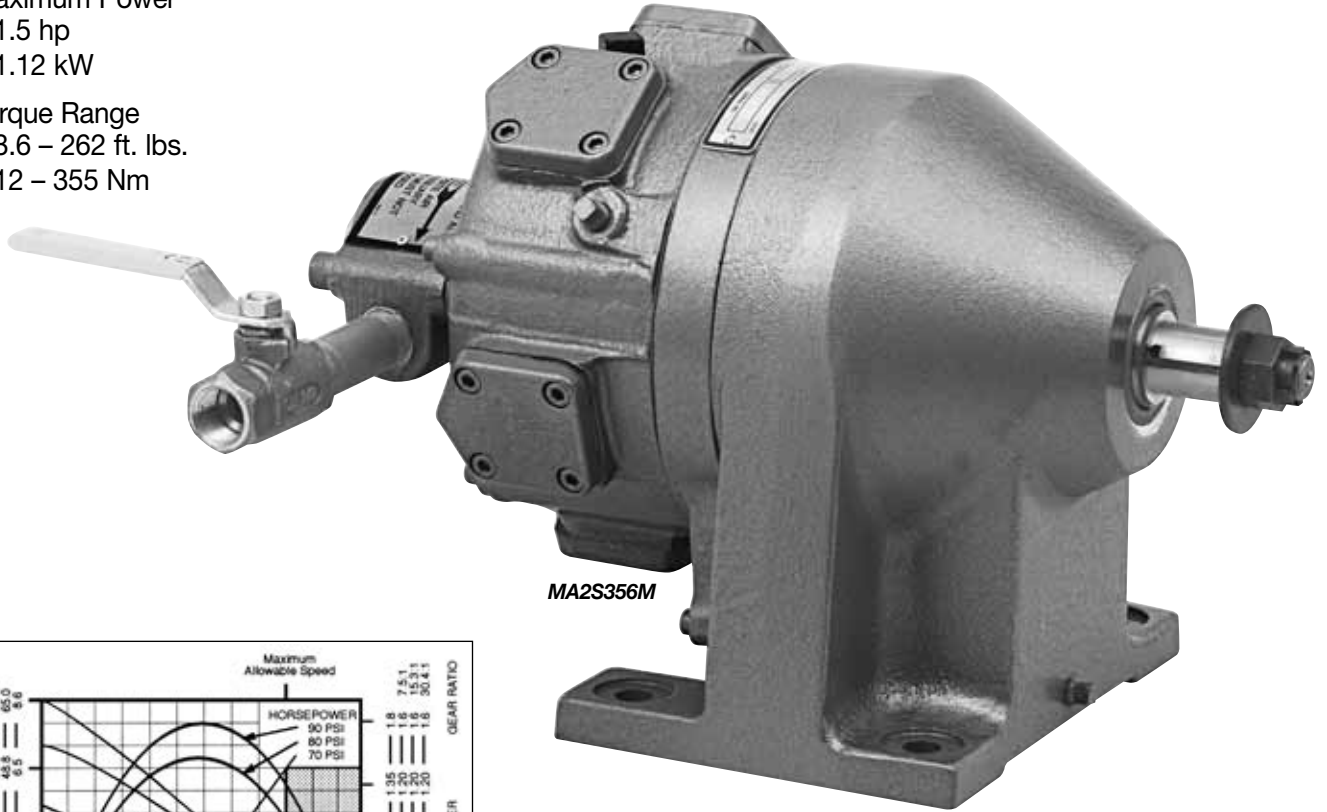

MA2S356M

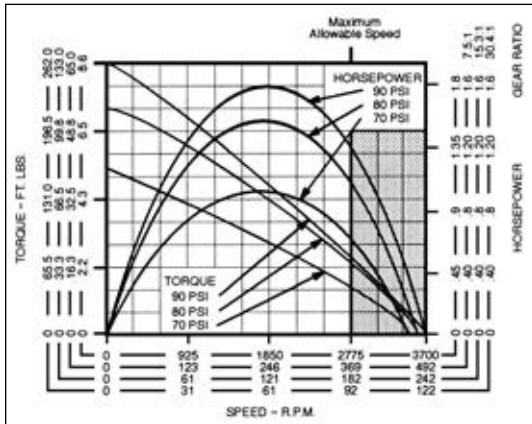

Model Number	RPM**		Stall Torque		Starting Torque		Weight		Air Consumption		Gear Ratio	Max. Overhung Load @ Stall*	
	at Max. hp	Free Speed	ft. lbs.	Nm	ft. lbs.	Nm	lbs.	kg	cfm	m ³ /min		lbs.	kg

with Single-Direction Valving

MA2S356M	246	490	65.0	88	30	41.0	40	18.1	65	1.84	7.5:1	1700	771
MA2S352M	61	120	262.0	355	122	165.0	40	18.1	62	1.76	30.4:1	1700	771

with Reversible Valving

MA2R355M	119	240	133.0	180	61	83.0	43	19.5	54	1.53	15.3:1	1700	771
MA2R353M	60	120	262.0	355	122	165.0	43	19.5	58	1.64	30.4:1	1700	771

without Valving

MA3W404M	119	240	133.0	180	61	83.0	43	19.5	54	1.53	15.3:1	1700	771
MA3W403M	60	120	262.0	355	122	165.0	43	19.5	58	1.64	30.4:1	1700	771

*All models assume overhung load located at 0.625" (15.88mm) from face of motor.

**These motors must be operated with sufficient load to prevent speed from exceeding maximum allowable speed shown on performance curve.

General:

Air Inlet: 1/2" NPTF

All tools performance rated @ 90psi (620 kPa) air pressure.

Optional Equipment:

Lubricating Oil – Part 533485 (1 gallon)

Gear Oil – Part 535090 (1 gallon)

Additional Accessories: Pages 64-65

MA2 Series Dimensional Data

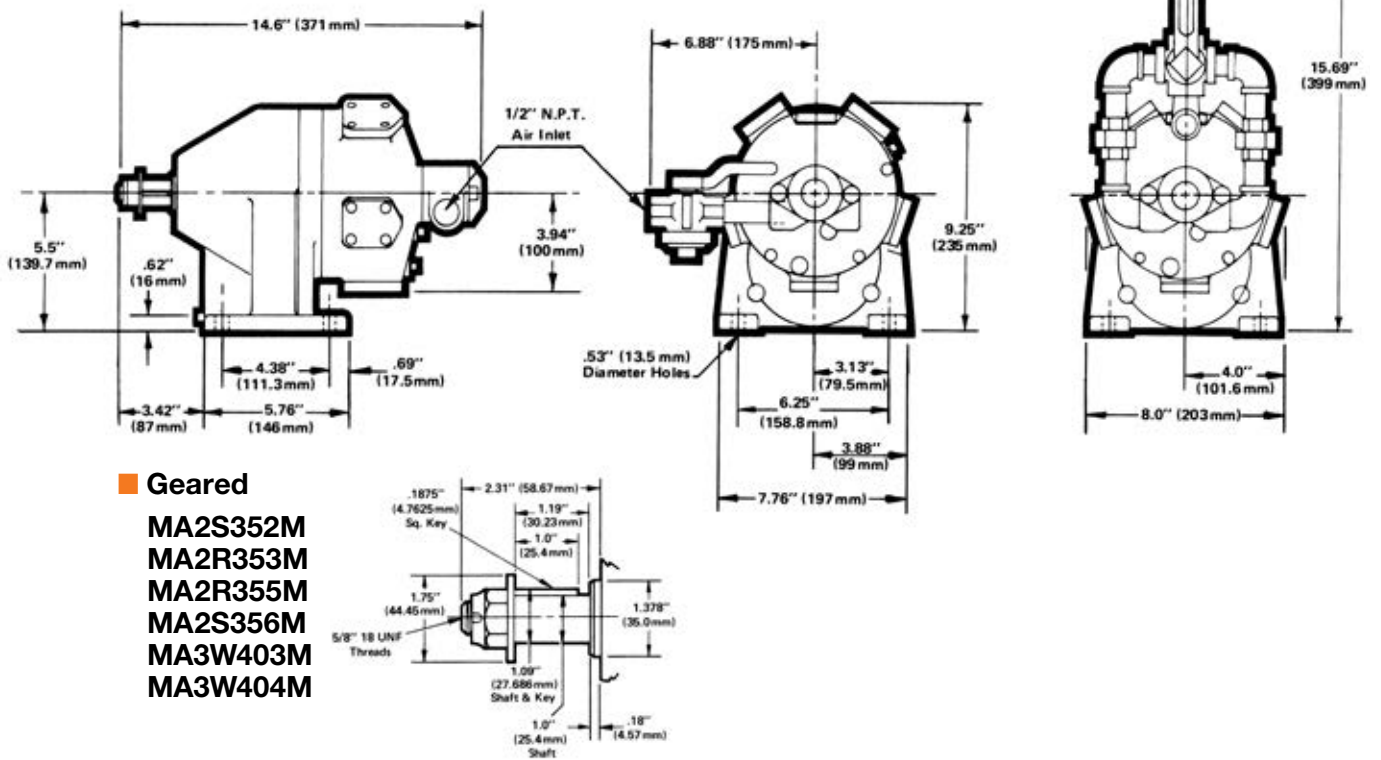

Geared

- MA2S352M
- MA2R353M
- MA2R355M
- MA2S356M
- MA3W403M
- MA3W404M

Cleco®

MA3 Series

- Maximum Power
3.0 hp
2.24 kW
- Torque Range
24 – 588 ft. lbs.
33 – 797 Nm

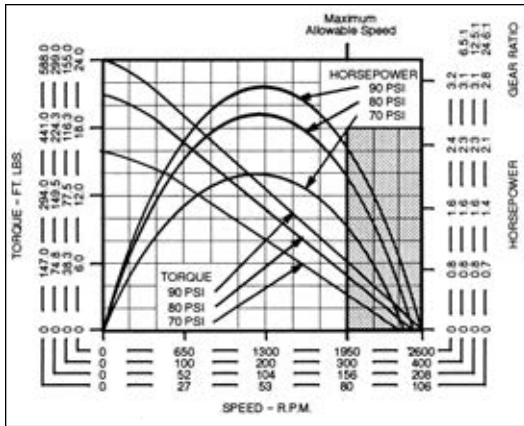
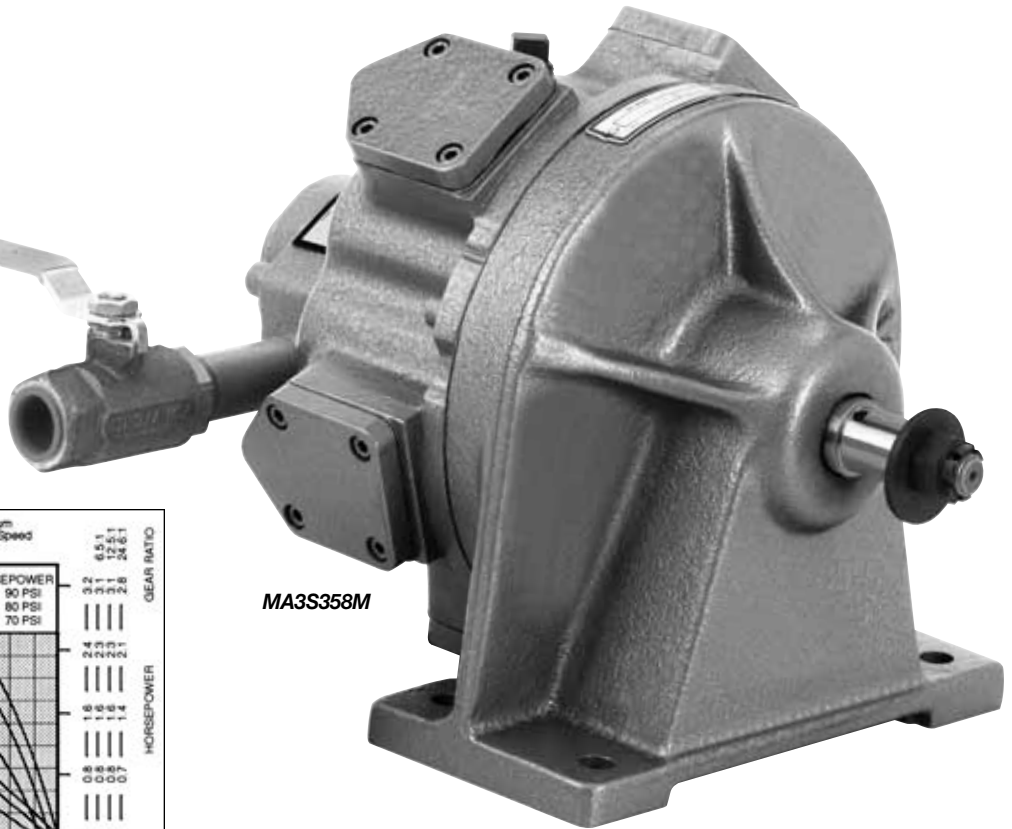

Model Number	RPM**		Stall Torque		Starting Torque		Weight		Air Consumption		Gear Ratio	Max. Overhung Load @ Stall*	
	at Max. hp	Free Speed	ft lbs.	Nm	ft lbs.	Nm	lbs.	kg	cfm	m ³ /min		lbs.	kg
with Single-Direction Valving													
MA3S358M	1300	2600	24	33	13	18	49	22.2	90	2.55	—	750	340
MA3S372M	200	400	155	210	84	114	65	29.5	90	2.55	6.5:1	2560	1161
MA3S370M	104	200	299	405	161	218	65	29.5	88	2.49	12.5:1	2560	1161
MA3S360M	53	100	588	797	317	430	65	29.5	97	2.74	24.6:1	2560	1161
with Reversible Valving													
MA3R359M	1190	2600	24	33	13	18	51	23.1	80	2.27	—	750	340
MA3R373M	183	400	155	210	84	114	67	30.1	87	2.46	6.5:1	2560	1161
MA3R371M	95	200	299	405	161	218	67	30.1	90	2.55	12.5:1	2560	1161
MA3R361M	48	100	588	797	317	430	67	30.1	95	2.69	24.6:1	2560	1161
without Valving													
MA3W406M	1190	2600	24	33	13	18	51	23.1	80	2.27	—	750	340
MA3W409M	183	400	155	210	84	114	67	30.1	87	2.46	6.5:1	2560	1161
MA3W408M	95	200	299	405	161	218	67	30.1	90	2.55	12.5:1	2560	1161
MA3W407M	48	100	588	797	317	430	67	30.1	95	2.69	24.6:1	2560	1161

* Non-geared models assume overhung load located at 0.625" (15.88mm) from face of motor.
Geared models assume overhung load located at 1" (25.40mm) from face of motor.

**These motors must be operated with sufficient load to prevent speed from exceeding maximum allowable speed shown on performance curve.

General:
Air Inlet: 3/4" NPTF
All tools performance rated @ 90psi (620 kPa) air pressure.

Optional Equipment:
Lubricating Oil – Part 533485 (1 gallon)
Gear Oil – Part 535090 (1 gallon)

MA3 Series Dimensional Data

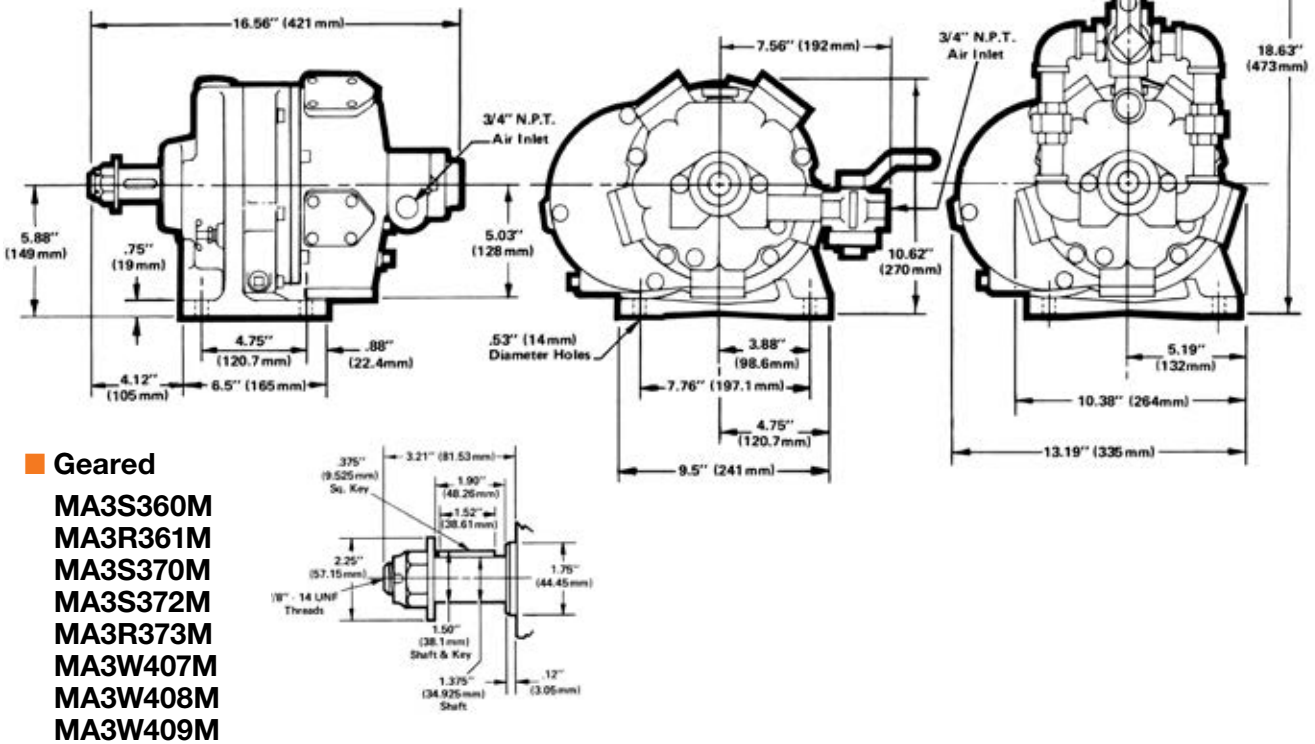
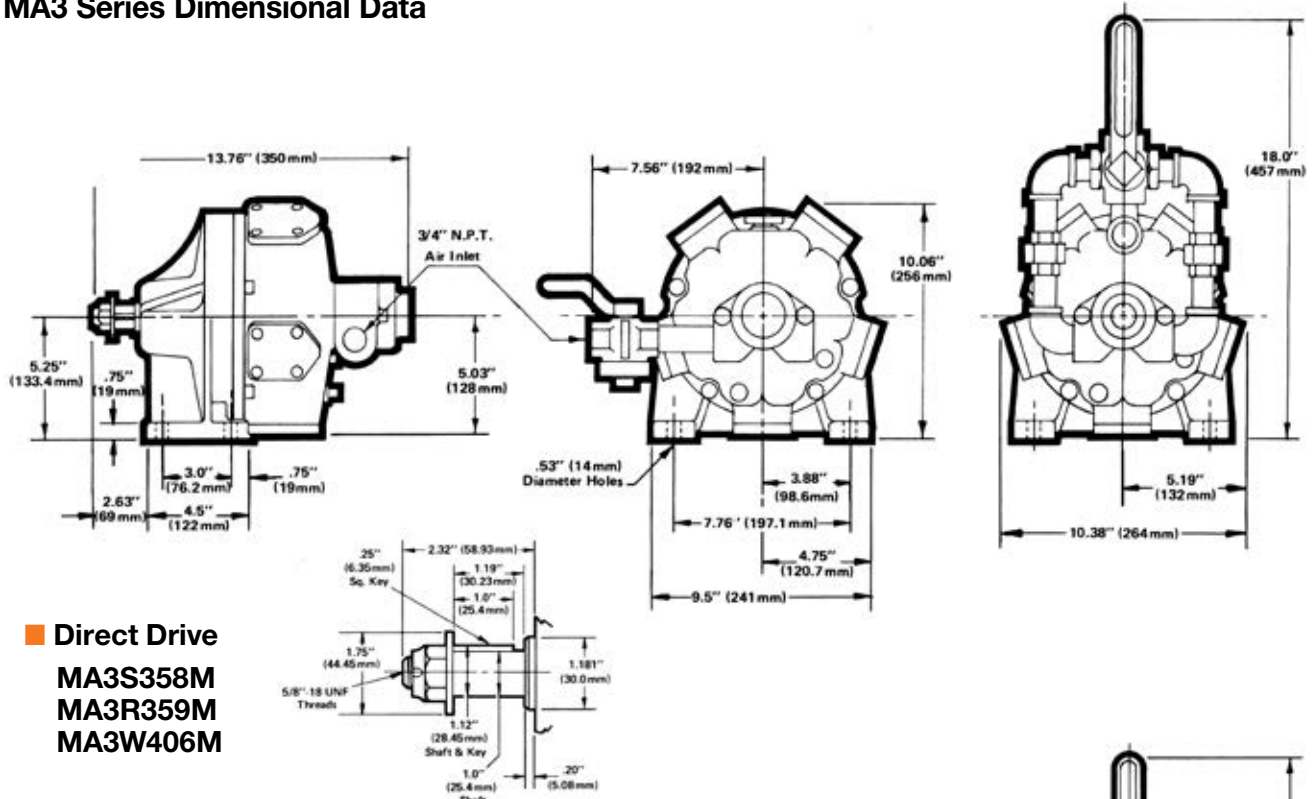



MB Series

- Maximum Power
5.5 hp
4.10 kW
- Torque Range
34 – 700 ft. lbs.
46 – 949 Nm

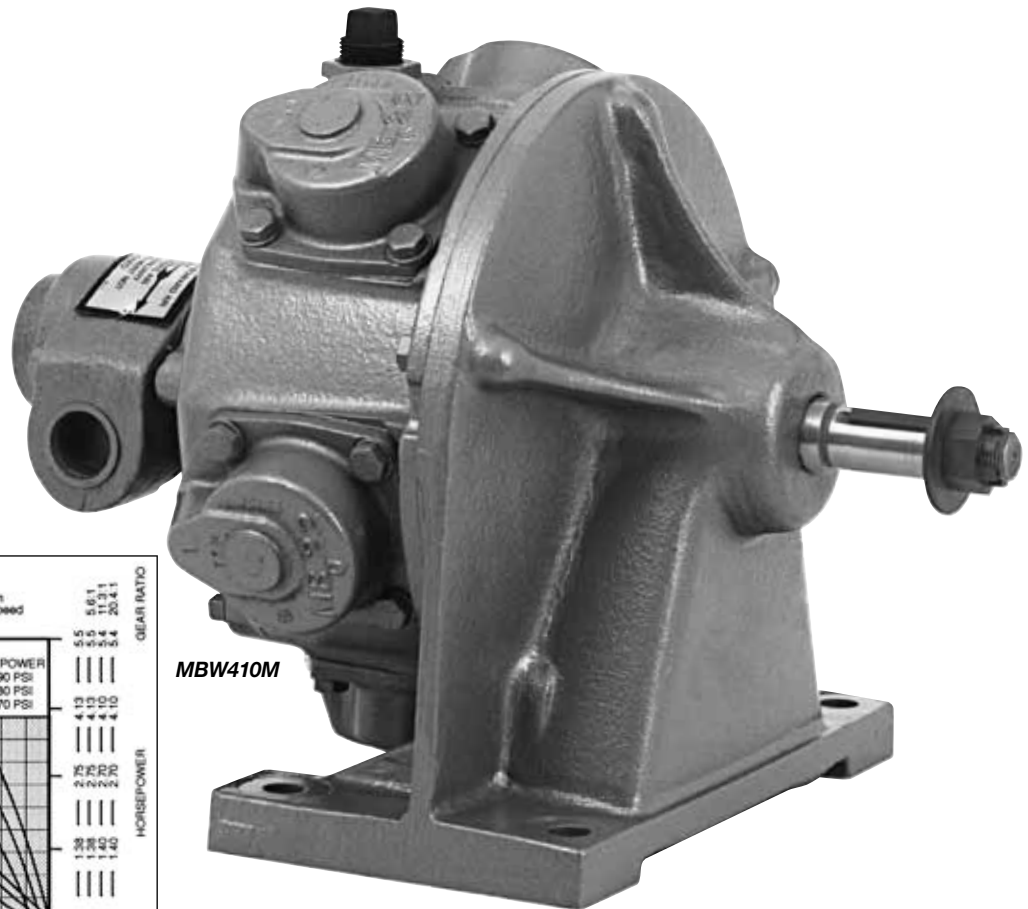

MBW410M

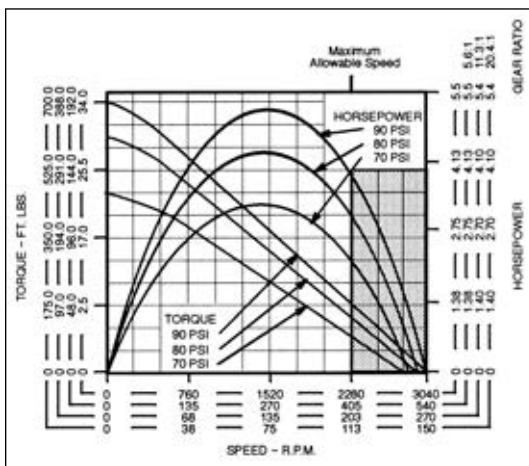

Model Number	RPM**		Stall Torque		Starting Torque		Weight		Air Consumption		Gear Ratio	Max. Overhung Load @ Stall*	
	at Max. hp	Free Speed	ft lbs.	Nm	ft lbs.	Nm	lbs.	kg	cfm	m ³ /min		lbs.	kg
with Single-Direction Valving													
MBS374M	1520	3000	34	46	15	20	100	45.4	166	4.70	—	1310	594
MBS380M	270	540	192	260	81	110	145	65.8	144	4.08	5.6:1	2200	998
MBS376M	75	150	700	949	296	401	145	65.8	167	4.73	20.4:1	2200	998
with Reversible Valving													
MBR381M	268	540	192	260	81	110	148	67.1	140	3.96	5.6:1	2200	998
MBR379M	133	270	388	526	164	222	148	67.1	148	4.19	11.3:1	2200	998
MBR377M	74	150	700	949	296	401	148	67.1	154	4.36	20.4:1	2200	998
without Valving													
MBW410M	1500	3000	34	46	15	20	103	46.7	152	4.30	—	1310	594
MBW413M	268	540	192	260	81	110	148	67.1	140	3.96	6.5:1	2200	998
MBW412M	133	270	388	526	164	222	148	67.1	148	4.19	11.3:1	2200	998
MBW411M	74	150	700	949	296	401	148	67.1	154	4.36	20.4:1	2200	998

* All models assume overhung load located at 1" (25.40mm) from face of motor.

**These motors must be operated with sufficient load to prevent speed from exceeding maximum allowable speed shown on performance curve.

General:

Air Inlet: 1" NPTF

All tools performance rated @ 90psi (620 kPa) air pressure.

Optional Equipment:

Lubricating Oil – Part 533485 (1 gallon)

Gear Oil – Part 535090 (1 gallon)

MB Series Dimensional Data

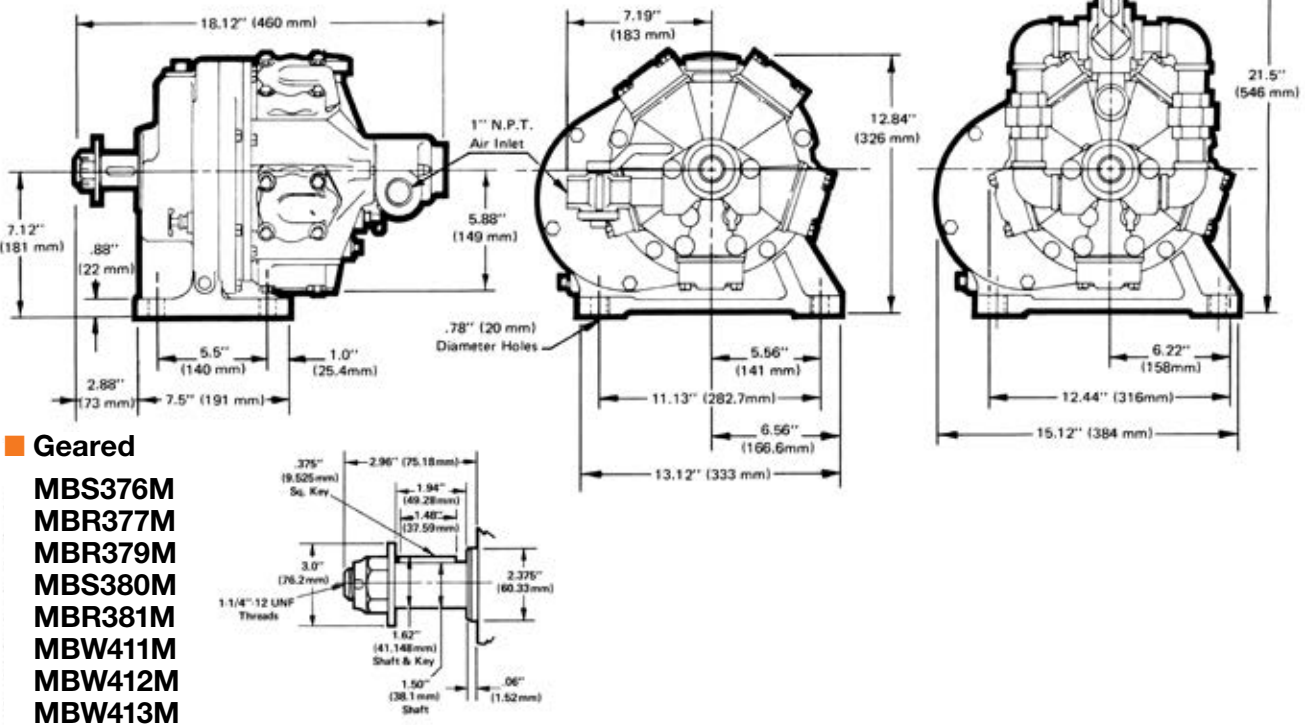
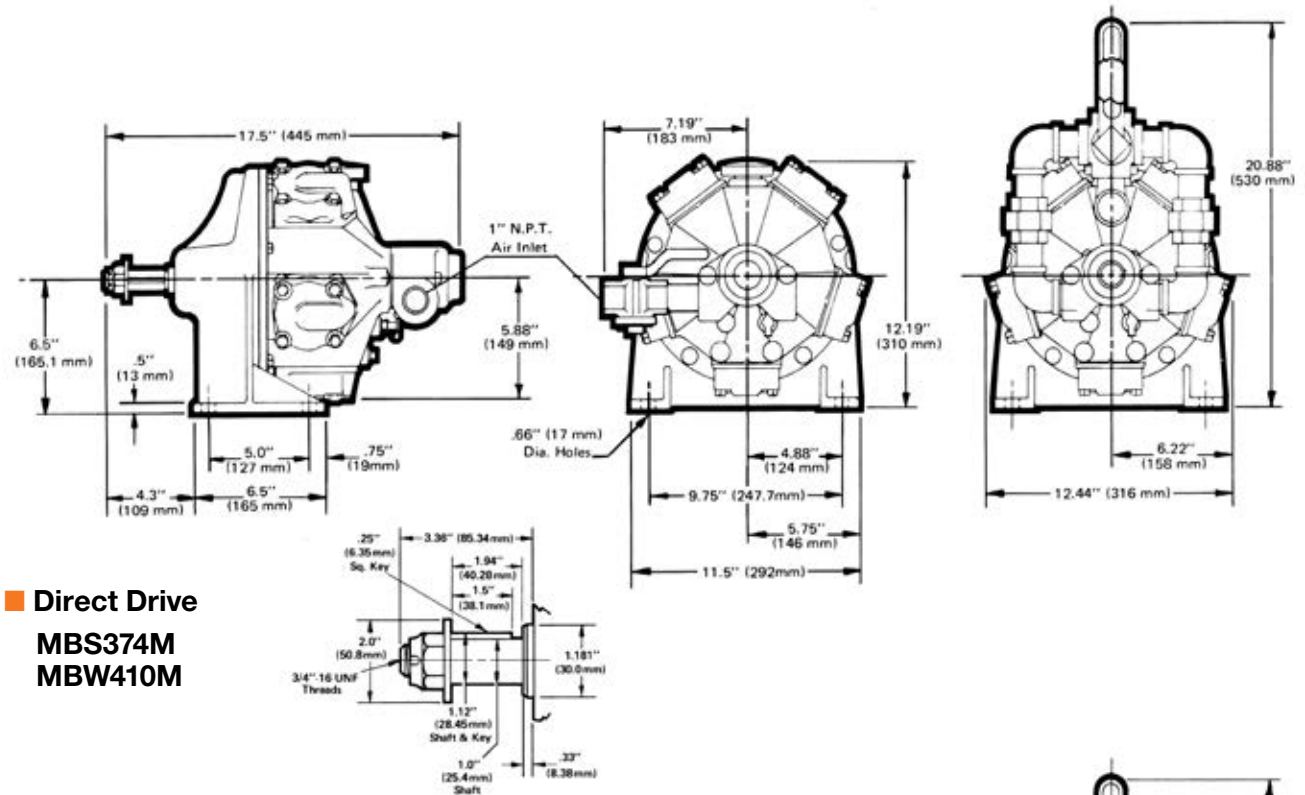

Cleco®

ME Series

- Maximum Power
6.5 hp
4.85 kW
- Torque Range
48 – 985 ft. lbs.
65 – 1336 Nm

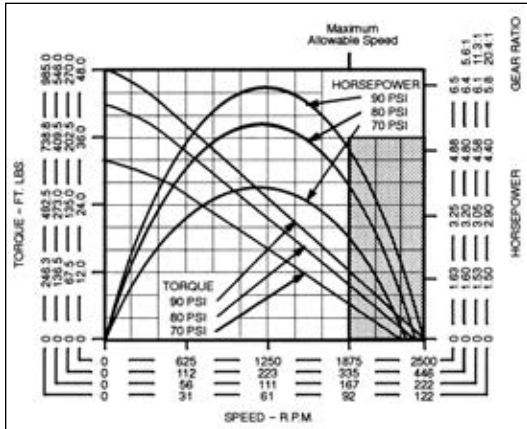

Model Number	RPM**		Stall Torque		Starting Torque		Weight		Air Consumption		Gear Ratio	Max. Overhung Load @ Stall*	
	at Max. hp	Free Speed	ft lbs.	Nm	ft lbs.	Nm	lbs.	kg	cfm	m ³ /min		lbs.	kg
with Single-Direction Valving													
MES386M	111	220	546	740	209	283	153	69.4	169	4.79	11.3:1	2200	998
MES384M	61	120	985	1336	377	511	153	69.4	168	4.76	20.4:1	2200	998
with Reversible Valving													
MER389M	219	440	270	366	104	141	157	71.2	152	4.30	5.6:1	2200	998
MER387M	108	220	546	740	209	283	157	71.2	171	4.84	11.3:1	2200	998
MER385M	60	120	985	1336	377	511	157	71.2	167	4.73	20.4:1	2200	998
without Valving													
MEW414M	1225	2500	48	65	19	26	104	47.2	161	4.56	—	1310	594
MEW417M	219	440	270	366	104	141	157	71.2	152	4.30	6.5:1	2200	998
MEW415M	60	120	985	1336	377	511	157	71.2	167	4.73	20.4:1	2200	998

* All models assume overhung load located at 1" (25.40mm) from face of motor.

**These motors must be operated with sufficient load to prevent speed from exceeding maximum allowable speed shown on performance curve.

General:

Air Inlet: 1" NPTF

All tools performance rated @ 90psi (620 kPa) air pressure.

Optional Equipment:

Lubricating Oil – Part 533485 (1 gallon)

Gear Oil – Part 535090 (1 gallon)

ME Series Dimensional Data

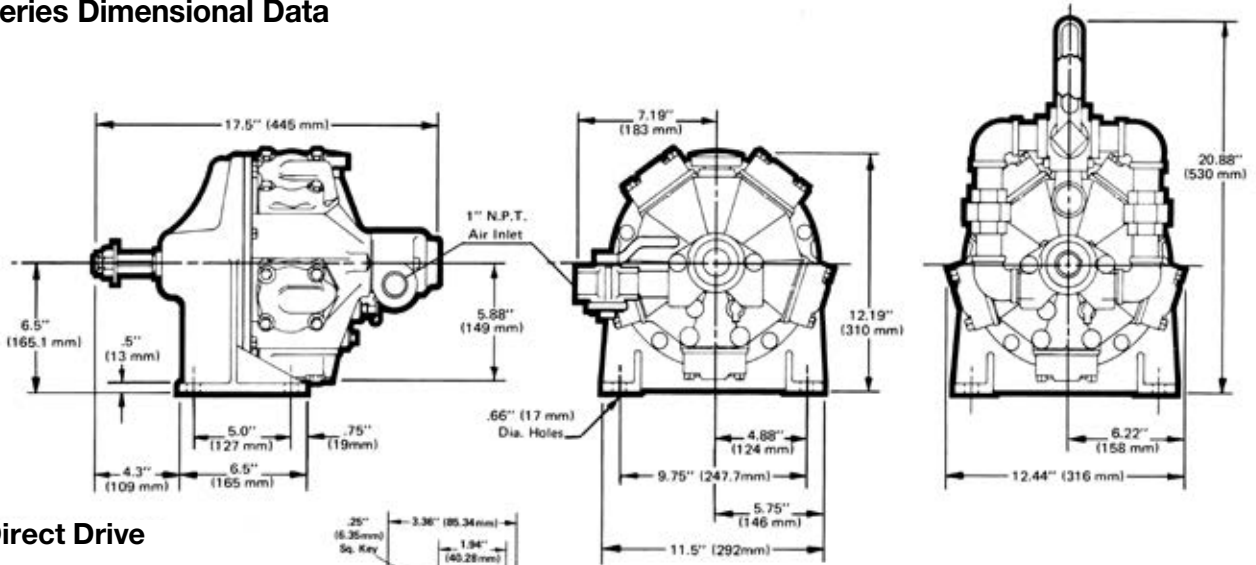

■ **Direct Drive**
MEW414M

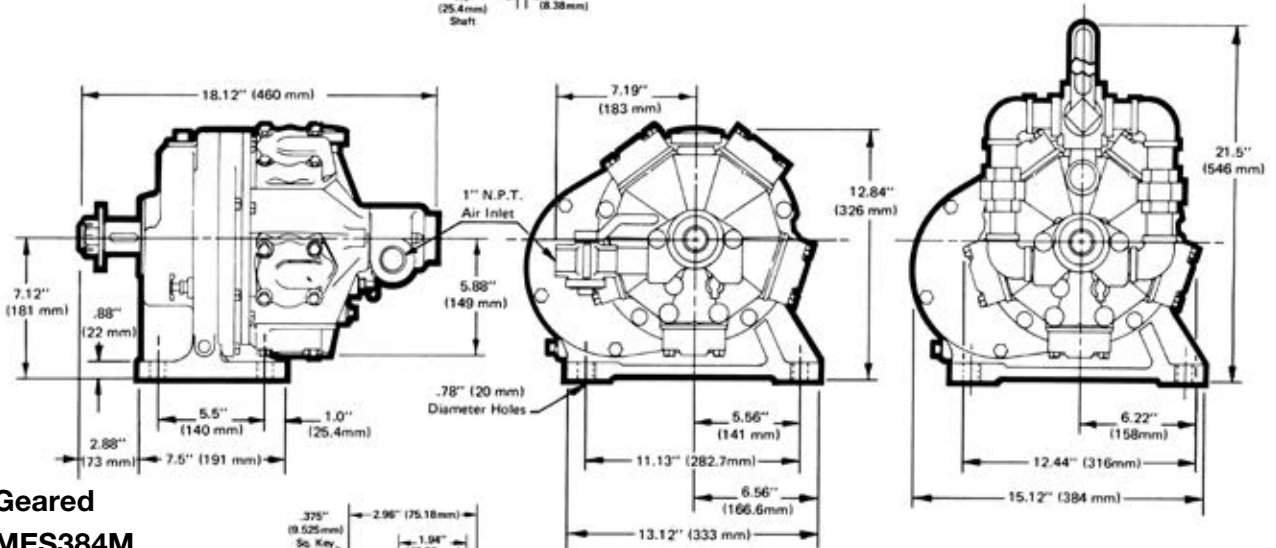
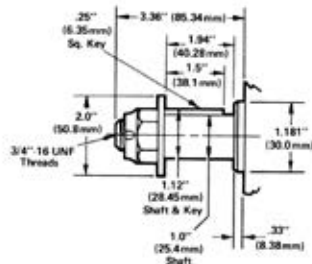

■ **Geared**
MES384M
MER385M
MES386M
MER387M
MER389M
MEW415M
MEW417M

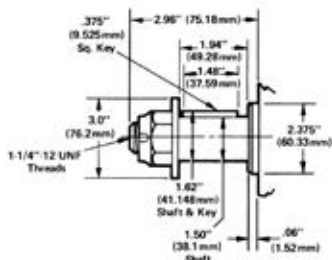

Cleco®

MK Series

- Maximum Power
 - 11 hp
 - 8.20 kW
- Torque Range
 - 117 – 1654 ft. lbs.
 - 159 – 2243 Nm

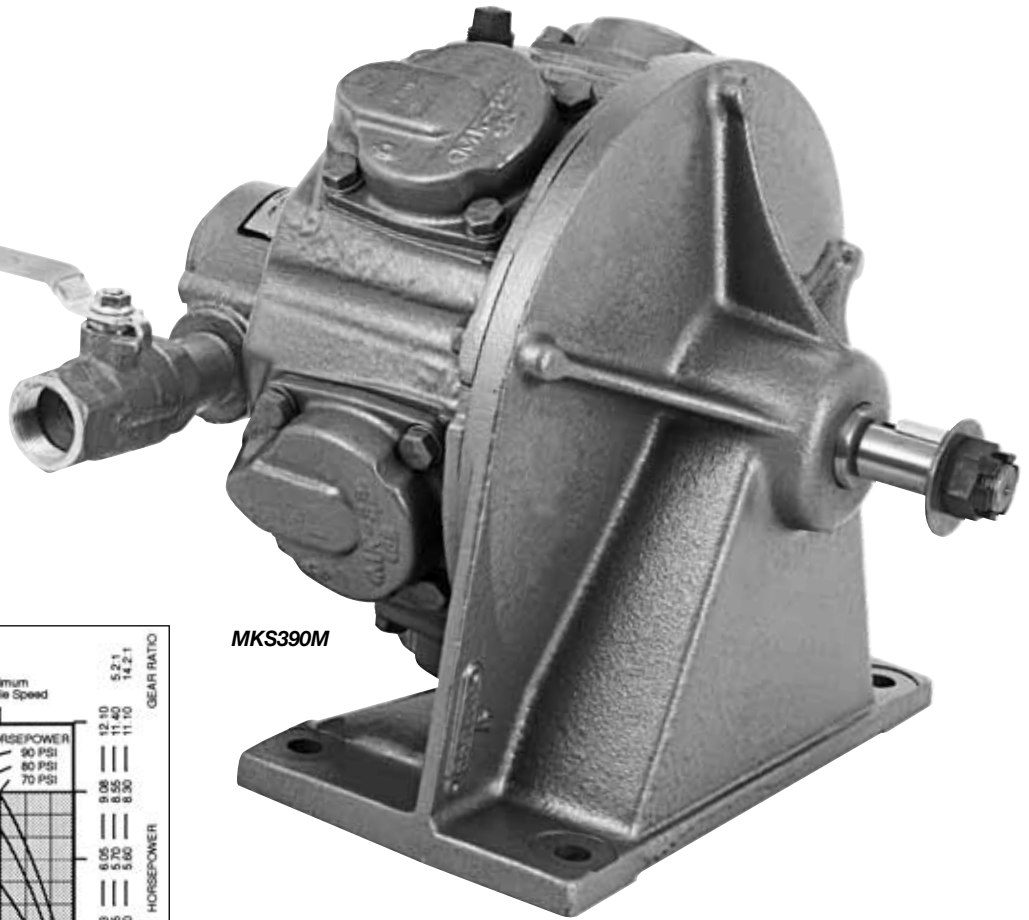

MKS390M

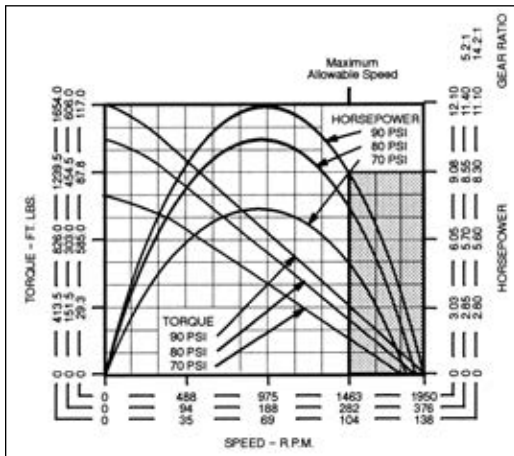

Model Number	RPM**		Stall Torque		Starting Torque		Weight		Air Consumption		Gear Ratio	Max. Overhung Load @ Stall*	
	at Max. hp	Free Speed	ft lbs.	Nm	ft lbs.	Nm	lbs.	kg	cfm	m ³ /min		lbs.	kg

with Single-Direction Valving

MKS390M	975	1900	117	159	72	98	195	88.5	302	8.55	—	2500	1134
MKS392M	69	135	1654	2243	1021	1384	225	102.1	293	8.30	14.2:1	2800	1270

with Reversible Valving

MKR391M	975	1900	117	159	72	98	202	91.6	311	8.81	—	2500	1134
MKR395M	183	375	606	822	374	507	230	104.3	299	8.47	5.2:1	2800	1270
MKR393M	67	135	1654	2243	1021	1384	230	104.3	288	8.16	14.2:1	2800	1270

without Valving

MKW418M	975	1900	117	159	72	98	104	91.6	311	8.81	—	2500	1134
MKW420M	183	375	606	822	374	507	230	104.3	299	8.47	5.2:1	2800	1270
MKW419M	67	135	1654	2243	1021	1384	230	104.3	288	8.16	14.2:1	2800	1270

* All models assume overhung load located at 1" (25.40mm) from face of motor.

**These motors must be operated with sufficient load to prevent speed from exceeding maximum allowable speed shown on performance curve.

General:

Air Inlet: 1-1/4" NPTF

All tools performance rated @ 90psi (620 kPa) air pressure.

Optional Equipment:

Lubricating Oil – Part 533485 (1 gallon)

Gear Oil – Part 535090 (1 gallon)

MK Series Dimensional Data

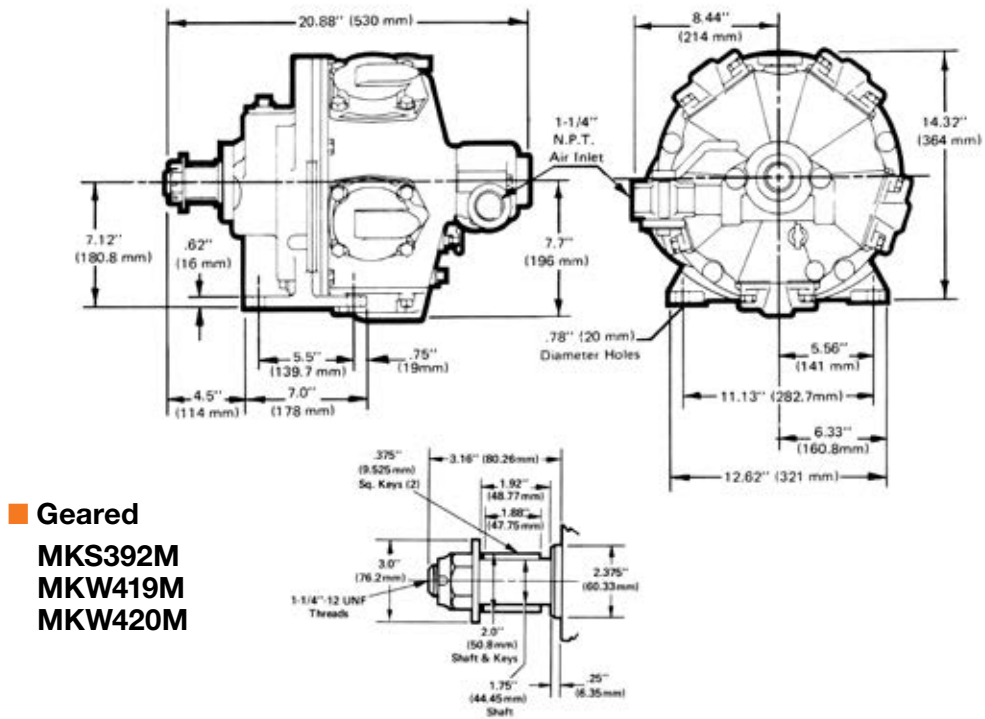
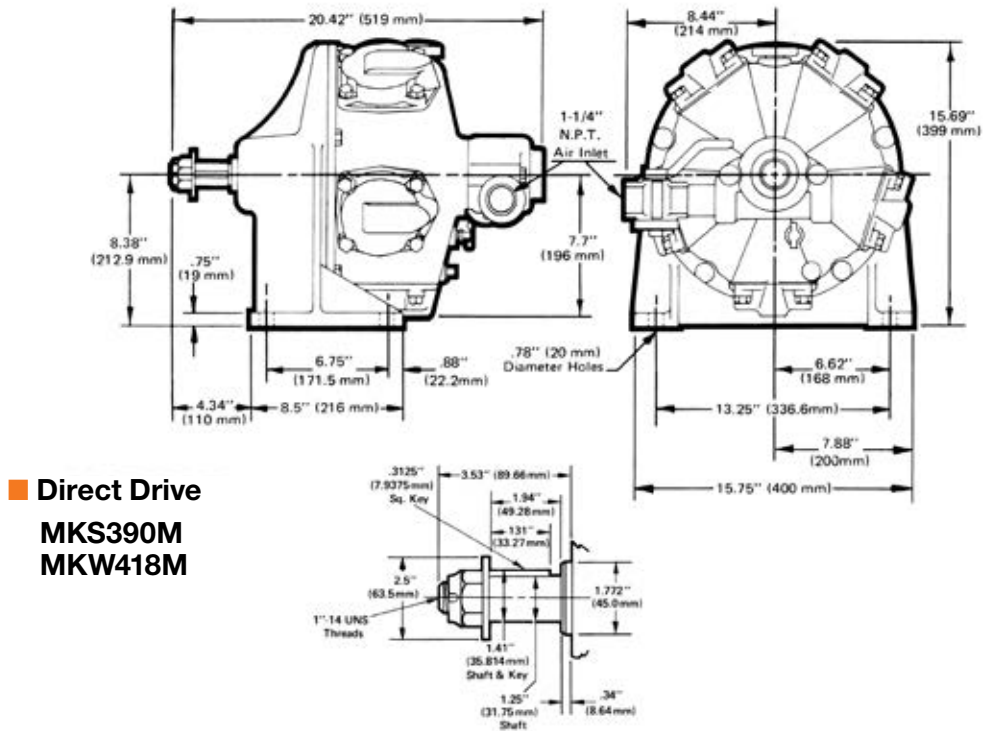

Radial Piston

Cleco®

MM Series

- Maximum Power
 - 15 hp
 - 11.19 kW
- Torque Range
 - 138 – 1952 ft. lbs.
 - 187 – 2647 Nm

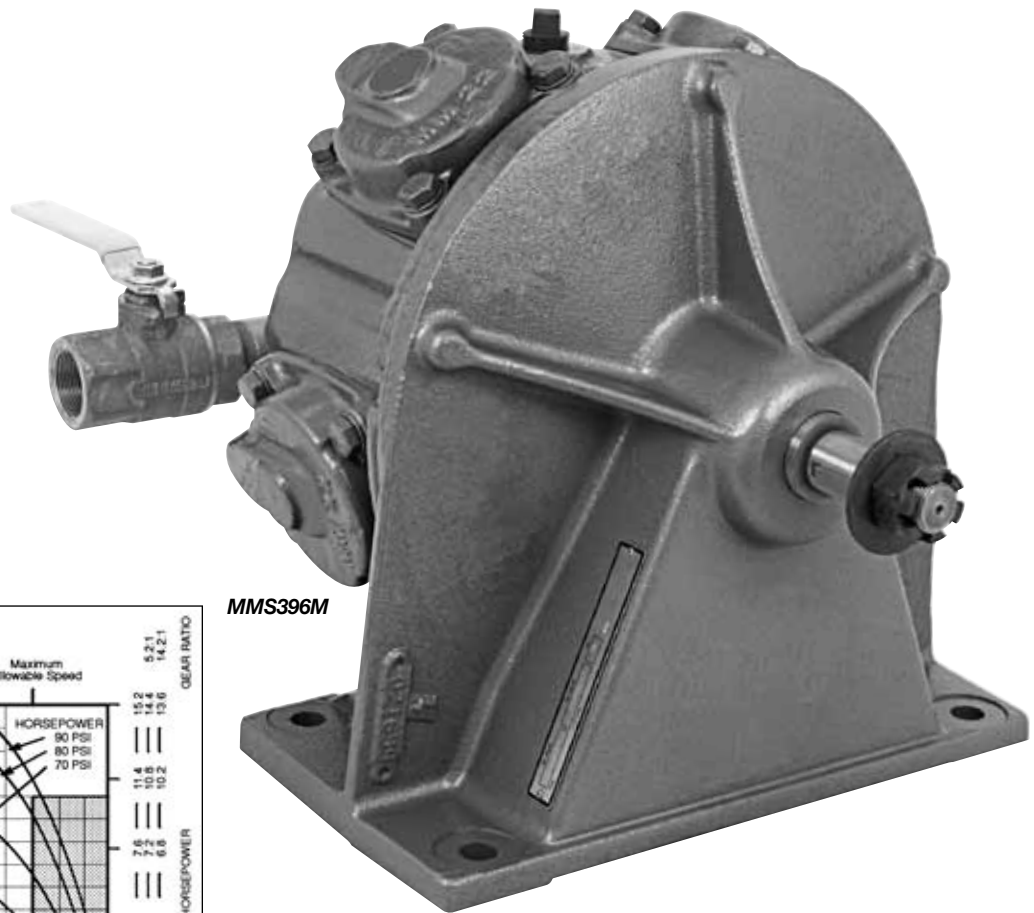

MMS396M

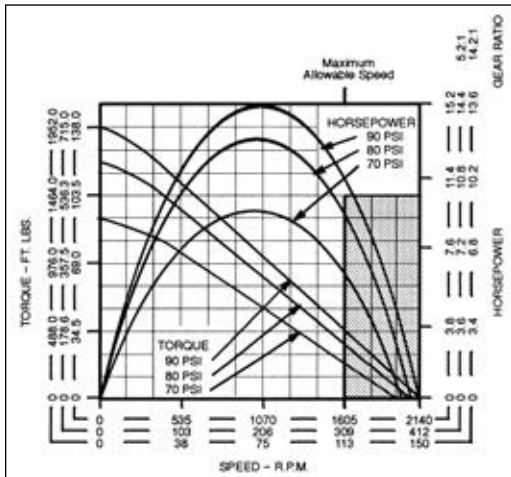

Model Number	RPM**		Stall Torque		Starting Torque		Weight		Air Consumption		Gear Ratio	Max. Overhung Load @ Stall*	
	at Max. hp	Free Speed	ft lbs.	Nm	ft lbs.	Nm	lbs.	kg	cfm	m ³ /min		lbs.	kg
with Single-Direction Valving													
MMS396M	1070	2100	138	187	82	111	210	95.3	348	9.86	—	2500	1134
MMS400M	206	400	715	970	424	575	226	102.5	336	9.52	5.2:1	2800	1270
with Reversible Valving													
MMR397M	1010	2100	138	187	82	111	214	97.1	352	9.97	—	2500	1134
MMR401M	194	400	715	970	424	575	231	104.8	332	9.40	5.2:1	2800	1270
MMR399M	71	150	1952	2647	1157	1569	231	104.8	345	9.77	14.2:1	2800	1270
without Valving													
MMW421M	1010	2100	138	187	82	111	214	97.1	352	9.97	—	2500	1134
MMW423M	194	400	715	970	424	575	231	104.8	332	9.40	5.2:1	2800	1270
MMW422M	71	150	1952	2647	1157	1569	231	104.8	345	9.77	14.2:1	2800	1270

* All models assume overhung load located at 1" (25.40mm) from face of motor.

**These motors must be operated with sufficient load to prevent speed from exceeding maximum allowable speed shown on performance curve.

General:

Air Inlet: 1-1/4" NPTF

All tools performance rated @ 90psi (620 kPa) air pressure.

Optional Equipment:

Lubricating Oil – Part 533485 (1 gallon)

Gear Oil – Part 535090 (1 gallon)

MM Series Dimensional Data

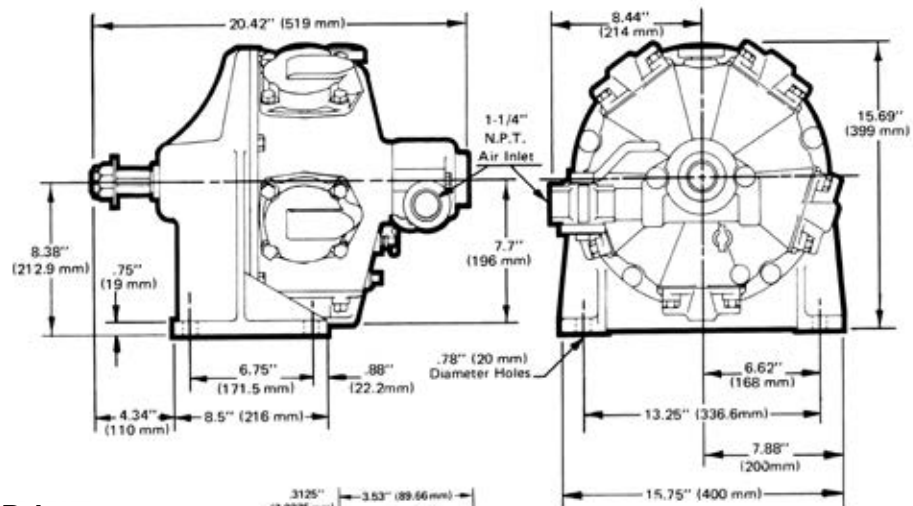

- Direct Drive
MMS396M
MMW421M

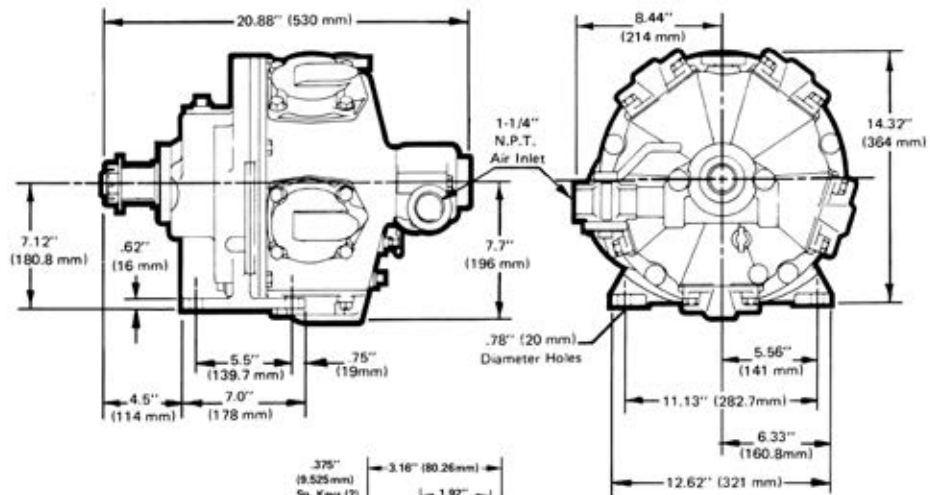
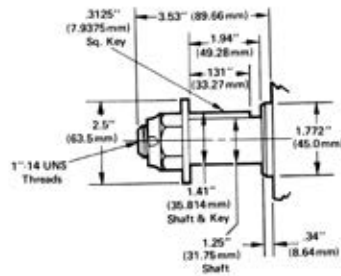

- Geared
MMS400M
MMW422M
MMW423M

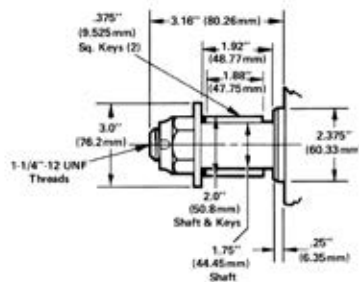

Throttle Combinations for Radial Piston Motors

Single Direction Valving

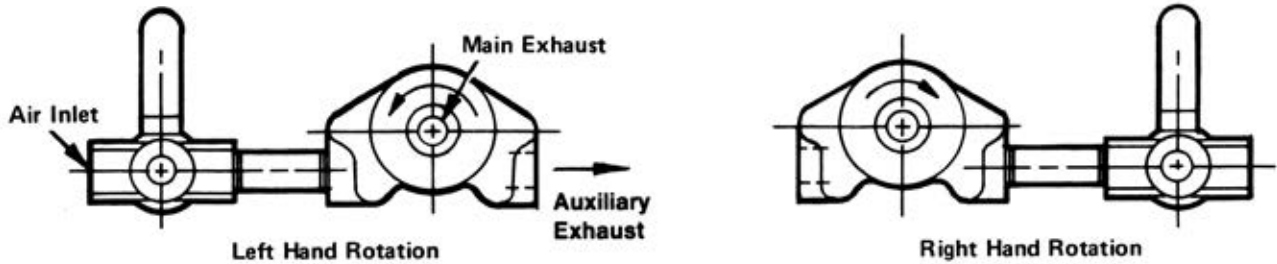

Reversible Valving

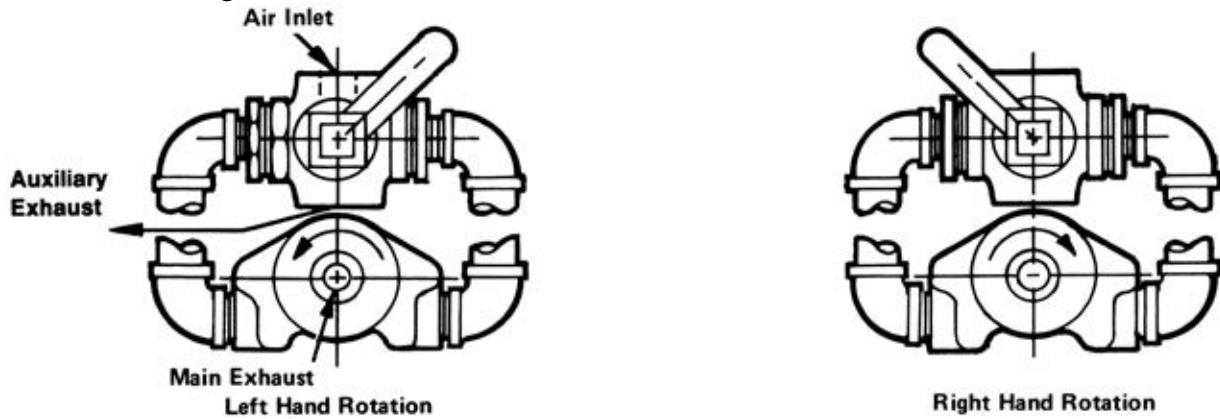

General Accessories

Filters, Lubricators

Modular Construction

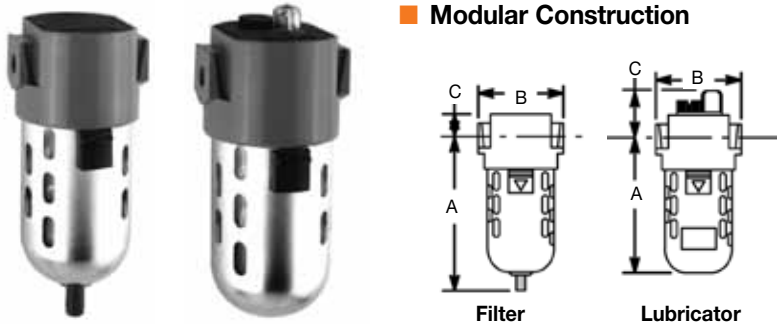

Model Number	NPT	Air Flow		Bowl Capacity		"A"		"B"		"C"	
	in.	SCFM	m ³ /min	oz.	liter	in.	mm	in.	mm	in.	mm
Filters											
F02-M	1/4	35	9.9	5.0	0.15	5.6	142	3.0	76	0.9	23
F03-M	3/8	44	12.9	5.0	0.15	5.6	142	3.0	76	0.9	23
Lubricators – Economist (Standard Mist)											
L03-EP	3/8	48	6.2	5.0	0.15	4.8	122	3.0	76	1.6	41

Modular Sleeve & Bracket (with O-Ring)

Model: MS-102

Combination sleeve/wall mounting bracket as shown. Designed for mounting a single unit or combination of units directly to the wall. The sleeve and mounting bracket can be ordered assembled at the factory, or just the mounting bracket alone to be used on existing modular sleeves.



Airline Filter and Lubricator



Part Number	Description	NPT	Air Flow		Max. Pressure	
		in.	SCFM	m ³ /min	psig	bar
45-0211	Filter w/cartridge*	1/4	17	8.0	100	6.9
45-0212	Filter cartridge	-	-	-	-	-
45-0201	Lubricator**	1/4	22	10	100	6.9
45-0301	Lubricator**	3/8	22	10	100	6.9

GENERAL: Use where inconvenient for standard filter or lubricator.

* NOTE: Filter will not remove water.

** NOTE: One ounce reservoir good for an average eight hour shift.



Air Hoses

Part Number	Hose I.D.		Fittings (NPT)		Length	
	in.	mm	in.	mm	ft.	m
A139856	3/16	4.7	1/8	1/8	6.0	1.8
45-1307	3/16	4.7	1/8	1/4	7.0	2.1
45-1408	1/4	6.4	1/4	1/4	8.0	2.4
45-1409	1/4	6.4	1/8	1/4	8.0	2.4
45-1508	5/16	7.9	1/4	1/4	8.0	2.4
45-1610	3/8	9.5	3/8	3/8	10	3.0
45-1810	1/2	12.7	3/8	1/2	10	3.0
45-1812	1/2	12.7	1/2	1/2	12	3.7
45-1825	1/2	12.7	1/2	1/2	25	7.6

GENERAL: 3/16" & 1/4" hoses have braided covers, all others have neoprene covers.

* NOTE: 3/8"-24 is a straight thread

Lubricants (do not substitute)

Oil –

- **Air Tool Oil #500021:**

Available in: 1 gal. can – part #533485

- **High Film Strength oil (for severe use):**

Available in: 1 gal. can – part #536333

NOTE: Cannot be used in AtoMist Lubricators. Use only with EconoMist or Servoil type lubricators.

- **MR Series Motors – Gearing Oil:**

Available in: 1 gal. can – part #535090

Grease –

Gear Lube:

Available in: 1 lb. can – part #A123771

1 gal. can – part #533485

NOTE: Same as Shell Oil Co. Alvania #EP RIO 71039 Grade "00" or Sun Petroleum Products Prestige 740 AEP Grade "00".

• Available On Quotation Basis Only

Swivel Hose Couplings

Part Number	NPT in.
A20744	1/4
A20741	3/8
A20764	1/2



Air Pressure Gage Kit

Part Number	Description
A13157	Gage, needle, cap & case



Quick Disconnect Fittings

Fitting Type*	NPT in.	Nominal Size		
		1/4"	3/8"	1/2"

Coupler (male NPT)

	1/8	45-0710	-	-
	1/4	45-0711	45-0713	-
	3/8	45-0712	-	-
	1/2	-	-	45-0717

Coupler (female NPT)

	3/8	45-0732	45-0734	45-0736
--	-----	---------	---------	---------

Nipple (male NPT)

	1/8	45-0720	-	-
	1/4	-	45-0724	-
	3/8	45-0722	45-0725	45-0726
	1/2	-	-	45-0727

Nipple (female NPT)

	1/4	-	45-0744	-
	3/8	45-0742	45-0745	45-0746
	1/2	-	-	45-0747

Nipple (with hose barbs)

	1/4**	45-0748	-	-
	1/2**	-	-	45-0753

* NOTE: Nipples of one size will not fit couplers of another size.

** NOTE: Indicates inside diameter of hose.

NOTE: 1/4" nominal will pass 49 cfm free air @ 90 psi, but pressure drop exceeds 10 psi with air flow over 30 cfm.

3/8" nominal will pass 90 cfm free air @ 90 psi, but pressure drop exceeds 10 psi with air flow over 53 cfm.

1/2" nominal will pass 168 cfm free air @ 90 psi, but pressure drop exceeds 10 psi with air flow over 109 cfm.

Conversion Tables

Millimeter – Decimal – Fraction

mm	Dec.	in.	mm	Dec.	in.	mm	Dec.	in.	mm	Dec.	in.	mm	Dec.	in.
0.100	.0039		5.159	.2031	13/64	10.200	.4016		15.300	.6024		20.300	.7992	
0.200	.0079		5.200	.2047		10.300	.4055		15.400	.6063		20.400	.8031	
0.300	.0118		5.300	.2087		10.319	.4063	13/32	15.478	.6094	39/64	20.500	.8071	
0.397	.0156	1/64	5.400	.2126		10.400	.4094		15.500	.6102		20.600	.8110	
0.400	.0157		5.500	.2165		10.500	.4134		15.600	.6142		20.638	.8125	13/16
0.500	.0197		5.556	.2188	7/32	10.600	.4173		15.700	.6181		20.700	.8150	
0.600	.0236		5.600	.2205		10.700	.4219		15.800	.6220		20.800	.8189	
0.700	.0276		5.700	.2244		10.716	.4219	27/64	15.875	.6250	5/8	20.900	.8228	
0.794	.0313	1/32	5.800	.2283		10.800	.4252		15.900	.6250		21.000	.8268	
0.800	.0315		5.900	.2323		10.900	.4291		16.000	.6299		21.034	.8182	53/64
0.900	.0354		5.953	.2344	15/64	11.000	.4331		16.100	.6339		21.100	.8307	
1.000	.0394		6.000	.2362		11.100	.4370		16.200	.6378		21.200	.8307	
1.100	.0433		6.100	.2402		11.113	.4375	7/16	16.272	.6406	41/64	21.200	.8346	
1.191	.0469	3/64	6.200	.2441		11.200	.4409		16.300	.6417		21.300	.8386	
1.200	.0472		6.300	.2480		11.300	.4449		16.400	.6457		21.400	.8425	
1.300	.0512		6.350	.2500	1/4	11.400	.4488		16.500	.6496		21.431	.8438	27/32
1.400	.0551		6.400	.2520		11.500	.4528		16.600	.6535		21.500	.8465	
1.500	.0591		6.500	.2559		11.509	.4531	29/64	16.669	.6563	21/32	21.600	.8504	
1.588	.0625	1/16	6.600	.2598		11.600	.4567		16.700	.6575		21.700	.8543	
1.600	.0630		6.700	.2638		11.700	.4606		16.800	.6614		21.800	.8583	
1.700	.0669		6.747	.2656	17/64	11.800	.4646		16.900	.6654		21.828	.8594	55/94
1.800	.0709		6.800	.2677		11.900	.4685		17.000	.6693		21.900	.8622	
1.900	.0748		6.900	.2717		11.906	.4688	15/32	17.066	.6719	43/64	22.000	.8661	
1.984	.0781	5/64	7.000	.2756		12.000	.4724		17.100	.6732		22.100	.8701	
2.000	.0878		7.100	.2795		12.100	.4764		17.200	.6772		22.200	.8740	
2.100	.0827		7.144	.2813	9/32	12.200	.4803		17.300	.6811		22.225	.8750	7/8
2.200	.0866		7.200	.2835		12.300	.4843		17.400	.6850		22.300	.8780	
2.300	.0906		7.300	.2874		12.303	.4844	31/64	17.463	.6875	11/16	22.400	.8819	
2.381	.0938	3/32	7.400	.2913		12.400	.4882		17.500	.6890		22.500	.8858	
2.400	.0945		7.500	.2953		12.500	.4921		17.600	.6929		22.600	.8898	
2.500	.0984		7.541	.2969	19/64	12.600	.4961		17.700	.6968		22.622	.8906	57/64
2.600	.1024		7.600	.2992		12.700	.5000	1/2	17.800	.7008		22.700	.8937	
2.700	.1063		7.700	.3031		12.800	.5039		17.859	.7031	45/64	22.800	.8976	
2.778	.1094	7/64	7.800	.3071		12.900	.5079		17.900	.7047		22.900	.9016	
2.800	.1102		7.900	.3110		13.000	.5118		18.000	.7087		23.000	.9055	
2.900	.1142		7.938	.3125	5/16	13.097	.5156	33/64	18.100	.7126		23.019	.9063	29/32
3.000	.1181		8.000	.3150		13.100	.5157		18.200	.7165		23.100	.9094	
3.100	.1220		8.100	.3189		13.200	.5197		18.256	.7188	23/32	23.200	.9134	
3.175	.1250	1/8	8.200	.3228		13.300	.5236		18.300	.7205		23.300	.9173	
3.200	.1260		8.300	.3268		13.400	.5276		18.400	.7244		23.400	.9213	
3.300	.1299		8.334	.3281	21/64	13.494	.5313	17/32	18.500	.7283		23.416	.9219	59/64
3.400	.1339		8.400	.3307		13.500	.5315		18.600	.7323		23.500	.9252	
3.500	.1378		8.500	.3346		13.600	.5354		18.653	.7344	47/64	23.600	.9291	
3.572	.1406	9/64	8.600	.3386		13.700	.5394		18.700	.7362		23.700	.9331	
3.600	.1417		8.700	.3425		13.800	.5433		18.800	.7402		23.800	.9370	
3.700	.1457		8.731	.3438	11/32	13.891	.5469	35/64	18.900	.7441		23.900	.9409	
3.800	.1496		8.800	.3465		13.900	.5472		19.000	.7480		24.000	.9449	
3.900	.1535		8.900	.3504		14.000	.5512		19.050	.7500	3/4	24.100	.9488	
3.969	.1563	5/32	9.000	.3543		14.100	.5551		19.100	.7520		24.200	.9528	
4.000	.1575		9.100	.3583		14.200	.5591		19.200	.7559		24.209	.9531	61/64
4.100	.1624		9.128	.3594	23/64	14.288	.5625	9/16	19.300	.7598		24.300	.9567	
4.200	.1654		9.200	.3622		14.300	.5630		19.400	.7638		24.400	.9606	
4.300	.1693		9.300	.3661		14.400	.5669		19.447	.7656	49/64	24.500	.9646	
4.366	.1719	11/64	9.400	.3701		14.500	.5709		19.500	.7677		24.600	.9685	
4.400	.732		9.500	.3740		14.600	.5748		19.600	.7717		24.606	.9688	31/32
4.500	.1772		9.525	.3750	3/8	14.684	.5781	37/64	19.700	.7756		24.700	.9724	
4.600	.1811		9.600	.3780		14.700	.5787		19.800	.7795		24.800	.9764	
4.700	.1850		9.700	.3819		14.800	.5827		19.844	.7813	25/32	24.900	.9803	
4.763	.1875	3/16	9.800	.3858		14.900	.5866		19.900	.7835		25.000	.9843	
4.800	.1890		9.900	.3898		15.000	.5906		20.000	.7874		25.003	.9844	63/64
4.900	.1929		9.922	.3902	25/64	15.081	.5938	19/32	20.100	.7913		25.100	.9882	
5.000	.1969		10.000	.3937		15.100	.5945		20.200	.7953		25.200	.9921	
5.100	.2008		10.100	.3976		15.200	.5984		20.241	.7969	51/64	25.300	.9961	
												25.400	1.000	1

Conversion Tables

Torque – Air Pressure – Miscellaneous



Torque Conversion – In. Lbs. (Nm)					
In.	Nm	In.	Nm	In.	Nm
5	0.6	50	5.7	140	15.8
10	1.1	60	6.8	150	17.0
15	1.7	70	7.9	160	18.1
20	2.3	80	9.0	170	19.2
25	2.8	90	10.2	180	20.3
30	3.4	100	11.3	190	21.5
35	4.0	110	12.4	200	22.6
40	4.5	120	13.6		
45	5.1	130	14.7		

Torque Conversion – Ft. Lbs. (Nm)					
Ft. Lbs.	Nm	Ft. Lbs.	Nm	Ft. Lbs.	Nm
1	1.36	43	58.3	85	115.3
2	2.7	44	60.0	86	117.0
3	4.1	45	61.0	87	118.0
4	5.4	46	62.4	88	119.3
5	6.8	47	63.7	89	121.0
6	8.1	48	65.1	90	122.0
7	9.5	49	66.4	91	123.4
8	10.9	50	67.8	92	125.0
9	12.2	51	69.2	93	126.1
10	13.6	52	70.5	94	127.5
11	14.9	53	71.9	95	129.0
12	16.3	54	73.2	96	130.2
13	17.6	55	74.6	97	131.5
14	19.0	56	75.9	98	133.0
15	20.3	57	77.3	99	134.2
16	21.7	58	78.7	100	135.6
17	23.1	59	80.0	110	149.2
18	24.4	60	81.4	115	156.0
19	25.8	61	82.7	120	163.0
20	27.1	62	84.1	125	170.0
21	28.5	63	85.4	130	176.3
22	29.8	64	86.8	135	183.1
23	31.2	65	88.1	140	190.0
24	32.5	66	90.0	145	197.0
25	33.9	67	90.9	150	203.4
26	35.3	68	92.2	155	210.2
27	36.6	69	93.6	160	217.0
28	38.0	70	94.9	165	224.0
29	39.3	71	96.3	170	231.0
30	40.7	72	97.6	175	237.3
31	42.0	73	99.0	180	244.1
32	43.4	74	100.3	185	251.0
33	44.8	75	102.0	190	258.0
34	46.1	76	103.1	195	264.4
35	47.5	77	104.4	200	271.2
36	48.8	78	105.8	225	305.1
37	50.2	79	107.1	250	339.0
38	52.0	80	108.5	275	373.0
39	52.9	81	110.0	300	407.0
40	54.2	82	111.2	350	475.0
41	55.6	83	112.6	400	542.4
42	57.0	84	114.0		

Torque Conversion factors		
To Convert	Into	Multiply By
Inch Pounds	Foot Pounds	0.0835
Inch Pounds	Newton meters	0.1130
Inch Pounds	Kg-meters	0.0115
Inch Pounds	Kg-Cm	1.1519
Foot Pounds	Inch Pounds	12.000
Foot Pounds	Newton meters	1.3560
Foot Pounds	Kg-meters	0.1382
Foot Pounds	Kg-Cm	13.8240
Newton Meters	Inch Pounds	8.8440
Newton Meters	Foot Pounds	0.7370
Newton Meters	Kg-meters	0.1020
Newton Meters	Kg-Cm	10.2000
Kg meters	Inch Pounds	86.8100
Kg meters	Foot Pounds	7.2340
Kg meters	Newton-meters	9.8040
Kg Cm	Inch Pounds	0.8681
Kg Cm	Foot Pounds	0.0723
Kg Cm	Newton-meters	0.0980

Miscellaneous Conversion Factors		
To Convert	Into	Multiply By
Inches	Millimeters	25.4000
Millimeters	Inches	0.0394
Pounds	Kilograms	0.4536
Kilograms	Pounds	2.2050
psi	bar	0.069
bar	psi	14.5

Air Pressure Conversion		
PSI	kPa*	Bar**
85	586	5.9
90	620	6.2
95	655	6.6
100	690	6.9
125	860	8.6

* Preferred: Approximate to the nearest 5 kPa.
 ** Approximate to the nearest 0.5 Bar.

Apex Tool Group, LLC
1000 Lufkin Road
Apex, NC 27539
Phone: 919-387-0099
Fax: 919-387-2614
www.clecotools.com

Cleco®